



GEBRUIKERSHANDLEIDING / USERS MANUAL / BETRIEBSANLEITUNG
 MODE D'EMPLOI / MANUAL DE UTILIZACION / ISTRUZIONI PER L'USO
 BRUKSANVISNING

**MASS 12/60-2; 12/80-2; 12/150; 24/50-2; 24/75
 24/100; 48/25; 48/50; 3-24/100
 battery charger**



1	General information	16
2	Safety guidelines & measures	16
3	Installation	17
4	Start up & operation	21
5	Trouble shooting	23
6	Maintenance	24
7	Technical data	25
8	EC declaration of conformity	27
9	Data sheets	Appendix A / B / C



1 GENERAL INFORMATION

GUARANTEE SPECIFICATIONS

Mastervolt guarantees the performance of this MASS battery charger according to the specifications given in the data sheets, if installed and used as described in this manual. Should work take place, which is not in accordance with the guidelines, instructions and specifications contained in this users manual, then damage may occur and/or the unit may not fulfil its specifications. All of these matters may mean that the guarantee may become invalid.

The guarantee period is two years on materials and labour. Guarantee can only be given on products with an invoice.

QUALITY

Mastervolt products are produced under ISO 9001. In order to guarantee the quality during the production and prior to the delivery, all our products are exhaustively tested and inspected.

LIABILITY

Mastervolt can accept no liability for:

- damage due to use of the battery charger;
- possible errors in the manual and the results thereof.

2 SAFETY GUIDELINES & MEASURES

USE FOR INTENDED PURPOSE

The battery charger is constructed as per the applicable safety-technical guidelines. Use the battery charger only:

- for the charging of lead acid batteries (gel or wet) and the supply of loads attached to these batteries, in permanent systems;
- connected to a dedicated double pole circuit breaker (MCB);
- with a fuse, protecting the wiring between charger output and battery;
- in a technical correct condition;
- in a closed, well-ventilated room, protected against rain, moist, dust and non condensing circumstances.



Never use the battery charger at locations where there is danger of gas- or dust explosion!

Use other than as mentioned under 2 is not considered to be consistent with the intended purpose. Mastervolt is not liable for any damage resulting from the above.

SAFETY

1 Use only fuses with the prescribed current level:

- AC supply fuse not greater than is required for the current consumption;
- The charger fuse must be large enough for the maximal charger current and small enough to protect the charger's output cables.

2 Check the wiring at least once a year. Defects such as loose connections, burned cables etc. must be corrected immediately.

3 Do not work on the charger or the system if it is still connected to a current source. Only allow changes in your electrical system to be carried out by qualified electricians.

4 Connection and protection must be done in accordance with local standards.

5 Before opening the cabinet of the charger, switch off the mains and remove the charger fuse, which is integrated in the system wiring.

3 INSTALLATION

Please check the contents of the box before you start with the installation. The contents of the box needs to be as follows:

- battery charger;
- temperature sensor (incl. 6 mtr cable);
- users manual;
- quick start installation guide.

If one of the abovementioned items is missing, please contact your supplier.

Install the MASS battery charger in a dry, well ventilated area, as close as possible to the batteries. Although the battery charger has a high efficiency, some heat will be produced. This heat will be discharged by a fan with variable speed. At installation of the battery charger be sure that:

- the air flow is not obstructed;
- no water and/or dust can enter the cabinet.

MOUNTING THE MASS CHARGER

The charger can be either horizontal or vertically mounted. We recommend vertical, because the heat convection is from bottom to top. Please keep a space of at least 10 cm around the charger for optimal cooling.

CONNECTIONS

Before making the connection between the battery charger and the system be sure that the AC and DC system are switched off. Remove the fuses in order to prevent yourself for unexpected start up.

AC POWER CONNECTION

Check if the voltage of your mains source or generator correspond with the working voltage of the battery charger as mentioned on the type number plate, located inside the unit (on the left side).

Cut the cable in accordance to fig. 1a. It is important that the green/ yellow earth wire is ± 1 cm longer than the other wires. By accidently pulling at the cable, the earth wire stays longer connected to the charger which gives additional safety. Connect the green/yellow wire to PE, brown to L1 and the blue wire to the N terminal.

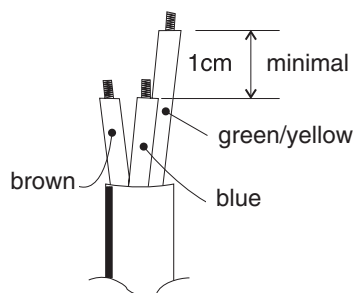

Fig. 1a.

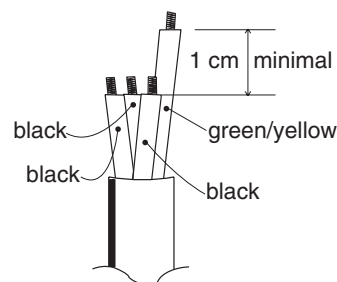

Fig. 1b.

Connect the 3-24/100 according to fig. 1b. The three black wires to L1, L2 and L3. Connect the green/yellow wire to the PE.

Battery wires

Keep the cable connection between charger and batteries as short as possible. If possible use coloured battery cables. If this is not possible, mark the plus and the minus cables with coloured insulating tape, e.g. red for plus and blue/black for minus. Use the following diameters:

charge current	length up to 3 meter	length up to 6 meter
25A	10 mm ²	16 mm ²
50 --> 60A	25 mm ²	35 mm ²
75 --> 100A	35 mm ²	50 mm ²
100 --> 150A	50 mm ²	70 mm ²

Connection of main batteries

- 1 Pull the cables through the cable glands of the charger.
- 2 Crimp on the ring terminals to the cable:
 - ring M6 for 12/60-2, 12/80-2, 24/50-2 and 48/25;
 - ring M8 for 12/150, 24/75, 24/100, 48/50 and 3-24/100.
- 3 Connect the cables to the terminals of the charger. Pay attention to the polarity, plus on plus / minus on minus.
- 4 Integrate a suitable fuse (charger fuse) in the plus cable (see chapter 7 for the values). When using a DC distribution with fuses, no additional fuse is necessary.
- 5 Cut the cables at length and crimp on the ring terminals. Connect the cable to the DC distribution or batteries.



Reversing the plus and the minus will severely damage the charger.



Too thin cables and/or loose connections can cause dangerous overheating of the cables and/or terminals.

Therefore tighten all connections properly, in order to limit as much as possible transition resistance, and use battery cables with the correct diameter.

Battery isolator

If one or more batteries or battery sets must be charged at the same time via one output, a battery isolator should be used. A battery isolator isolates the different battery sets from one another, in order to prevent one discharging the other. A consequence of the battery isolator is a voltage drop of 0.6 Volt. This voltage drop can be compensated in 2 ways:

- 1 By altering the dip-switch settings;
- 2 Using the voltage sense function.



Warning !

Never use both methods. Your batteries will be overcharged and severely damaged.

Choose isolator type:

charge current	2 battery set	3 battery set
25 -> 50A	MV 702 MT	MV 703 MT
60 -> 80A	MV 1202 MT	MV 1203 MT
100A	MV 1602 MT	MV 1603 MT

For a proper installation, see also the connection diagram included with the battery isolator.

Steps:

- 1 Check if the charger, the main supply and the DC distribution are switched off.
- 2 Connect the battery isolator(s) using cables with the same diameter as the battery cables.
- 3 Compensate the voltage drop over the battery isolator by changing the setting of dip switch 4 (see fig. 2 and 3). Not necessary when using the voltage sense function.
- 4 Switch the charger on.

CONNECTION OF SECOND BATTERY (3A OUTPUT)

The battery chargers 12/60-2, 12/80-2 and 24/50-2 are standardly equipped with a second charge output of 3A in order to give a small second battery set like a starter battery a maintenance charge. The maximum charge current of the second output is 3A, which comes from the main output.

- Use 2.5 to 4 mm² cable for connection.
- Connect the minus of the second battery to the minus of the main battery.
- Connect the plus of the second battery to the +3A terminal of the charger (see fig. 2 and 3).
- Integrate a 10A slow blow fuse in the plus cable.

Temperature sensor

The standard temperature sensor is provided with 6 mtr cable and a double-sided tape for easy installation. Determine the warmest place on the battery set and make it clean and grease free. Remove the piece of paper from the tape and stick the sensor on the battery. Plug the 6-way cable into one of the two terminals at the right of the charger (see fig. 2 & 3). It does not matter which one, both "RS232" and "analog" are suitable. It is not necessary to shorten the cable. When you want to shorten it anyway please notice the polarity of the plug and use the old connector as an example.

Voltage sense

To shorten the charge time substantial the battery cable losses can be compensated by using the sense function. Use wire of 0,75 mm² preferable red and black and secure these with fuses of 2A slow blow.

Connect the wires with the two upper terminals of the green connector at the right side of the cabinet (see fig. 2 & 3). Pay good attention to the polarity of the wires, red on +S and black on -S. Now connect the other side of the wires: black on the minus of the battery and red on the battery side of the charger fuse. (See appendix C for installation examples).

Alarm function

The battery charger is equipped with an alarm relay with potential free contacts. The alarm function has two modes: standard (factory setting) and DC alarm mode (continue mode).

Standard:

In this mode the relay respond to all fault conditions that the charger can detect such as: no AC input voltage, too low DC voltage, voltage sense failure, temp. sense failure.

DC alarm mode:

To enable this mode a DIP switch setting needs to be changed (switch 1 and 2 at ON) The alarm now works as a DC alarm and responds only to the battery voltage. The alarm values can be found in Appendix A.

Note: In the DC alarm mode the electronics stay active permanently and drains a very small current of $\pm 25\text{mA}$, also when the charger is switched off.

CONNECTION OF ACCESSORIES

The battery charger is equipped with several terminals for accessories. Cable to connect the accessories is not delivered as a standard. Accessories can be plugged in at all times. When using a remote panel and the temperature sensor use the specified plug for the panel and the other (free) one for the temperature sensor.

**Basic remote panel C4-RB,
 art. no 07-04-04100**

The basic remote panel must be connected with a 6-way plug and cable. Connect the C4-RB panel with the most right terminal "analog".



**Standard remote panel C3-RS,
 art. no 07-04-03040**

The standard remote panel must be connected with a 6-way plug and cable. Connect the C3-RS panel to the middle terminal "RS232".

ADJUSTMENTS WITH DIP SWITCHES

The factory settings of the charge program is optimal for most installations. But in some special applications it is desirable to change the charge program. In order to change the charge parameters the charger is equipped with four tiny switches called DIP switches, see fig. 2 & 3 for the location and the set point information.

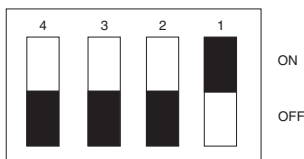
Changing the charge program is normally NOT necessary, the wrong adjustment can cause damage to your batteries.

The charger as float charger (Force Float)

For special applications a fixed charge voltage can be required. The battery charger allows you to change the 3-stage charge program to a single stage program by activating the function "ForcFloat" switching DIP switch 1 to "ON" (see fig. 2 & 3 for further information).

The charge voltage will be fixed at 13.25V (12V charger), 26.5V (24V charger) or 53V for a 48V charger.

Wet or gel batteries

Some gel batteries need a higher float voltage for optimal charge. Changing the float voltage can be done by setting DIP switch 3 to "ON". The float voltage will increase to 13.8V (12V charger), 27.6V (24V charger) or 55.2V for a 48V charger (see fig. 2 & 3 for further information).

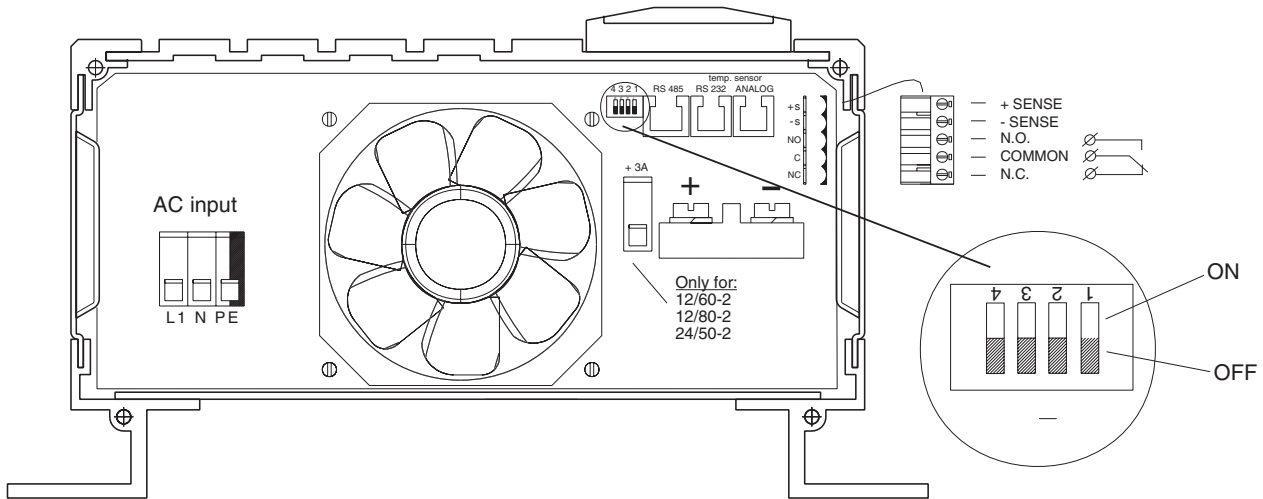

Fig. 2: Connections encl. 2.

DIP SWITCH SETTINGS

4	3	2	1	dip switches
0	0	0	0	Standard
1	0	0	0	Diode
0	1	0	0	Gel
1	1	0	0	Diode + Gel
0	0	1	0	Traction
1	0	1	0	Traction + Diode
0	1	1	0	ContMon + Traction
1	1	1	0	ContMon + Traction + Diode
0	0	0	1	ForceFloat
1	0	0	1	ForceFloat + Diode
0	1	0	1	ForceFloat + Gel
1	1	0	1	ForceFloat + Diode + Gel
0	0	1	1	ContMon
1	0	1	1	ContMon + Diode
0	1	1	1	ContMon + Gel
1	1	1	1	ContMon + Diode + Gel

1 = on; 0 = off

ContMon: Continuous monitor mode. The μ P and the RS485/RS232/DC alarm stays functioning at mains failure. The auxiliary power goes down but the remotes stay functioning if remote has own power source.

Diode: Diode compensation on (+0.6V).

Gel: Gel compensation on (+0,55V during float) or 1.1V/24V or 2.2V/48V.

Traction: Traction charging (+0.7V during bulk and +0.4V in absorption).

Force float: One step charge programme with fixed float voltage.

AC connections
3-24/100 charger.

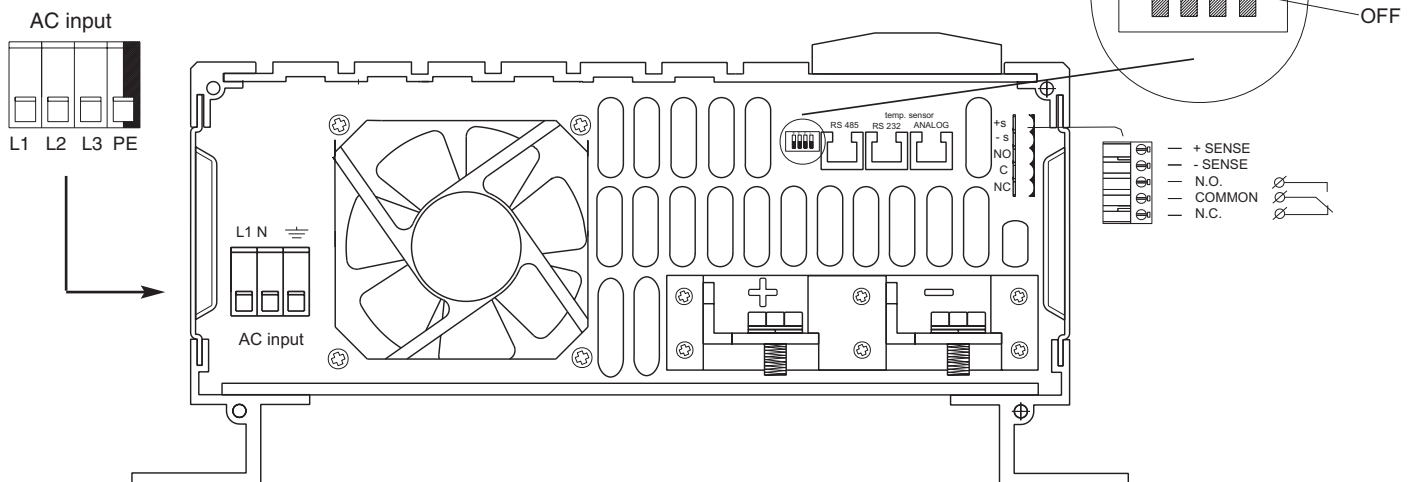

Fig. 3: Connections encl. 3.

4 START UP & OPERATION

INTRODUCTION

The MASS battery charger is a fully automatic highly-efficient battery charger/rectifier, developed and produced by Mastervolt Amsterdam. The MASS series goes with a family of advanced quality battery chargers. Mastervolt distributes these products worldwide. The battery charger possesses an outstanding charging technique in order to charge batteries rapidly, safely and at the same time supply the connected consumers. In addition, the charger is secured against short circuit, overload and high temperatures in an industrial environment.

- 1 Check if the charger is „OFF”.
- 2 Connect DC output with batteries or place fuse.
- 3 Switch on AC source.

Switching on:

The battery charger will be switched on by the ON switch. One of the front LEDs will light up now and the charging starts immediately.

Switching off:

The battery charger will be switched off by the OFF switch.



The connection between the mains and the battery charger will not be severed with the switch.

THEORY OF OPERATION

The battery charger is equipped with an intelligent 3-stage charge characteristic which takes care of an optimal charge of your batteries (see fig. 4). When switched on, the charger will first determine the battery status. Based on the measured values the best program will be started. This means that the charger can start anywhere in the program and not always at the beginning.

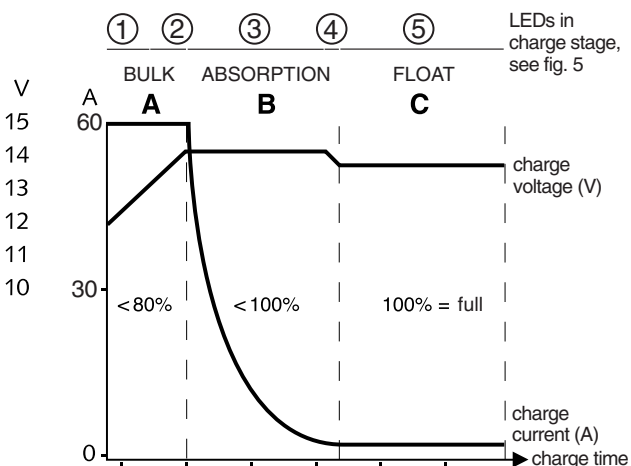

Fig. 4: Example: charge characteristic MASS 12/60-2.
(For other models V/A according to data sheets).

To prevent your batteries from overcharging a new cycle only starts when the battery voltage has been under the level of 12.8/25.6 or 51.2V for longer than 15 minutes or after a hard reset by switching the on/off switch back and forward.

On the front of the charger as well as on the optional remote panel a so called "capacity meter" gives you information about the battery state like a fuel meter of a car. The more LEDs are burning the more power is in the battery.

INDICATION LIGHTS

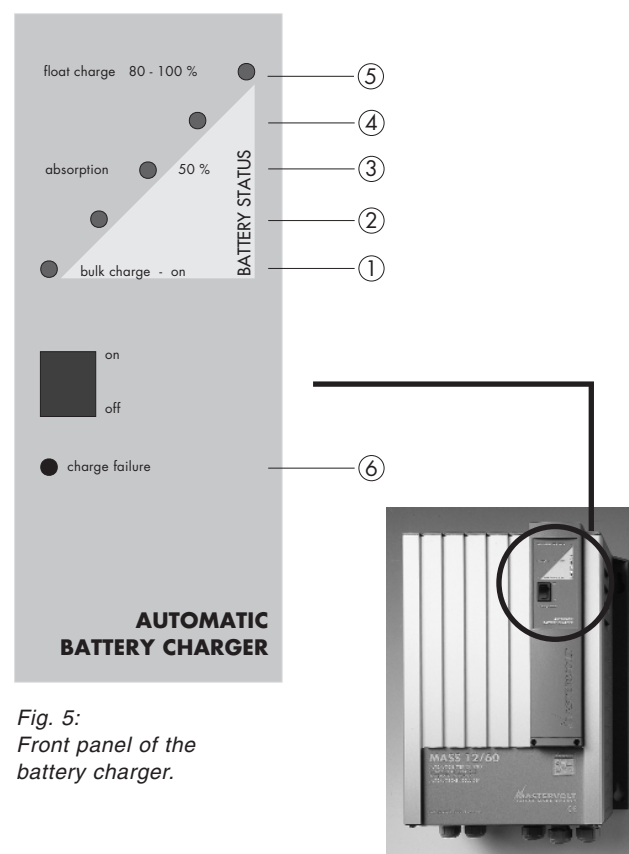

Fig. 5:
Front panel of the battery charger.

Illuminating LED's	Meaning
Normal operation	
1	charger on, I = max.
1 and 2	U out > 13.8/27.6/55.2V, I = max.
1, 2 and 3	U out = abs. (14.25/28.5/57V), I < max.
1, 2, 3 and 4	45 min. after start max. bulk timer, or I < return amps
1, 2, 3, 4 and 5	6 hours after start max. bulk timer, or I < return amps for 15 min. or longer
Fault condition	
6 and 1	battery sense error
6 and 2	charger temperature too high
6 and 3	short circuit indication, charger will reduce the charge current to 25%
6 and 4	DC error, DC voltage too low or too high
6 and 5	temperature sense error

Bulk (LED 1 is illuminating)

The battery is empty when only the first LED Bulk/ON illuminates. In this stage the charger gives full current (see fig. 4 phase A) and the battery voltage will slowly increase. After reaching the level of 13.8V (12V charger), 27.6V (24V charger) or 55.2V (48V charger) the battery is charged for about 25% and the second LED will also illuminate.



(LED 1 and 2 are illuminated)

The battery has been charged for 25%. The charger still gives the maximum output current and the voltage will increase till the absorption voltage level (see fig. 4 phase A). The maximum time of phase A can be 6 hours.

Absorption (LED 1, 2 and 3 are illuminated)

The battery has been charged for 50% (fig. 4 phase B). The charger limits the charge voltage to a safe level and the charge current shall slowly decrease.



(LED 1 till 4 are illuminated)

The battery is charged for 75%. The charge voltage is limited at the absorption level, because the battery is almost full, the current consumption will further decrease.

Float (LED 1 till 5 are illuminated)

When all LEDs are illuminated the battery is fully charged. The float/trickle charge program gives a lower output voltage, sufficient enough to maintain the batteries at 100% charge but low enough to prevent your batteries from unnecessary stress. In this stage the charger is able to supply full current to the connected users/loads.

TEMPERATURE COMPENSATED CHARGING

As a standard all Mastervolt battery chargers are delivered with a temperature sensor. Correct use of this temperature sensor can increase the battery's life time substantially which can save you a lot of money. The sensor measures the battery temperature and automatically adjusts the charge voltage to this.

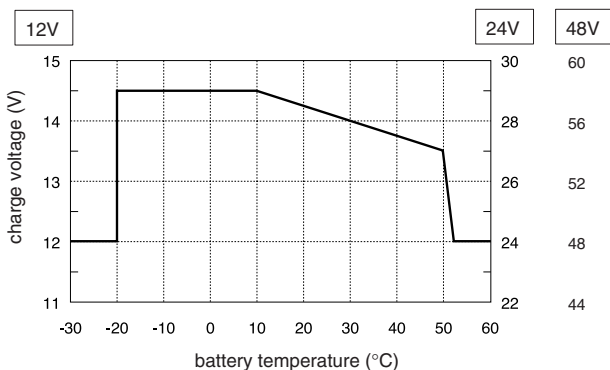

COMPENSATION OF THE CABLE LOSSES

The charger can compensate the voltage drop occurring over the DC cables. For this purpose the charger is provided with terminals for sense wires. The sense wires are connected on the end of the DC cables in order to charge the batteries with the right voltage. When only the minus sense wire is connected only the losses of the minus DC cable will be compensated. Connecting both cables gives the best result, all losses will be compensated until a maximum of 3V in total.

ALARM FUNCTION

The battery charger is equipped with an integrated alarm function. External equipment can be controlled by the potential free contacts of this alarm. The maximum switch current of the relay is 1A. Exceeding the setpoints will activate the alarm, setpoint values can be found in Appendix A.

CHARGING A SECOND BATTERY

Some installations have besides the main battery set a smaller (cranking) battery with the same voltage. It is possible to maintain this second battery with the 3A output of the battery charger. This function is as a standard available on the models 12/60-2, 12/80-2 and 24/50-2.

5 TROUBLE SHOOTING

Malfunction	Possible cause	What to do
No output voltage and/or current	No AC mains or fuse blows	Check fuse, replace if necessary.
	Mains or generator output too low	Check input voltage, must be between 190 and 260V (nominal 230V). For the 3-24/100 the input voltage must be between 360 and 485 Volt.
Output voltage too low but charger supplies max. current	Battery load consumes more than the charger can supply, the battery voltage cannot increase more	Reduce the battery load taken from batteries.
	Batteries not 100% charged	Measure the battery voltage after a while, this will be higher.
Charge current too low	Batteries almost fully charged	Check if the charger is in the absorption mode. In this mode, the charge current will slowly decrease.
	High ambient temperature	If the ambient temperature is more than 40°C, the maximum charge current automatically will be reduced.
	Mains too low	When the mains is lower than 207V, the charger will regulate the current down. At 180V the charge current is 0A. For the 3-24/100 this is 380V. At 352V the charge current will be 0A.
Batteries not fully charged	Charge current too low Current to load too high Charge time too short Battery temperature too low Defective battery (short circuit in cell)	See "charge current too low"; Decrease the battery load; Increase type of charger; Use temperature sensor; Replace the battery;
Battery loses charge quickly	Battery capacity reduced because: <ul style="list-style-type: none"> • wastage • sulphating/stagnation 	Replace the batteries; Charge/discharge several times, this might help, otherwise replace batteries.
Batteries are warm/gassing	Defective batteries (short circuit in cell) Battery temperature too high Charge voltage too high	Replace batteries; Use temperature sensor; Check the dip-switch setting.

If you cannot solve the problem with this fault finding table, contact your Mastervolt Service Centre.
For a detailed distributor list, please contact our main office in Amsterdam, tel. +31-20-3422100.
See also error code tabel in Appendix A.

6 MAINTENANCE

The battery charger requires no specific maintenance. For a reliable and optimal function of the MASS battery charger only the following is required:

- Check at least once a year the wire and cable connections (loosen joints etc.).
- Keep the MASS charger dry, clean and in a dust-free area, in order to ensure a good heat discharge.

CHARGING EFFICIENCY

For a good performance your batteries should not be discharged below 30-40% of their capacity. Therefore always start charging at this level.

As in marine and mobile systems often a limited charging time is desired, batteries are with generator use charged up to 85-90%. Charging up to 100% would take too long. This means that normally about 50% of the theoretical battery capacity can be used.

In case a mains connection is present, charging time is less important. Then charging up to 100% is advised.

TIPS TO INCREASE THE BATTERY LIFE TIME:

- Install the batteries at a cool place. The acid in the batteries will damage the plates in a high temperature environment. A normal life time of 5 years at 20°C, will go down to 2.5 years at 30°C.
- Charge the battery immediately after a consistent deep discharge. Especially at high environment temperatures, sulfating occurs very fast. If the state of sulfating is not too bad, the battery will regain a part of its capacity after a number of charge/recharge cycles.

7 TECHNICAL DATA 12/60-2, 12/80-2, 24/50-2 & 48/25

Function apparatus	battery charger/rectifier			
Manufacturer	Mastervolt, Amsterdam			

INPUT	12/60-2	12/80-2	24/50-2	48/25
Mains voltage	230V, -10% + 15% or 117V, -10% + 15%			
Frequency	50-60 Hz \pm 5 Hz			
Inrush current	none, the battery charger is equipped with a soft start in accordance with IEC 1003-3			
Current	4A (8A)**	6A (12A)**	7A (14A)**	7A (14A)**
Power factor (Cos phi)	1	1	1	1
Efficiency	89%	89%	89%	89%
Input power	900W	1400W	1600W	1600W

OUTPUT

Nominal voltage	12V DC	12V DC	24V DC	48V DC
Charge current	60A	80A	50A	25A
Outputs	1x60A and 1x3A	1x80A and 1x3A	1x50A and 1x3A	1x25A
Charge characteristic	three-step, fully automatic			
Kind of batteries	open and closed lead acid (gel or wet)			
Charge voltages at 25°C*				
• absorption	14.25V	14.25V	28.5V	57V
• float	13.25V	13.25V	26.5V	53V
Voltage ripple	max. 100mV RMS with resistive load @ full power			
Short circuit current (1/4 of max.)	15A	20A	12.5A	6.25A
Cable size (within 3 mtrs)	25 mm ²	35 mm ²	25 mm ²	10 mm ²
Charger fuse (external)	63A	100A	50A	25A

ENVIRONMENTAL

Ambient temperature	-20 to 40°C @ 100% output power, derated with 2,5% / °C 40°C
Cooling	forced air, by means of a ventilator with variable speed
Humidity	maximum 95% RV non condensing

ENCLOSURE (TYPE C2)

Dimensions (hwxwd) mm	333 x 261 x 144	333 x 261 x 144	333 x 261 x 144	333 x 261 x 144
Protection degree	IP23	IP23	IP23	IP23
Weight	5 kg	5 kg	5 kg	5 kg
Safety	IEC 335-2-29			
EMC emission	EN 50081-1			
EMC immunity	EN 50082-1			

* Depending on charge status and battery condition.

** At 117V mains voltage.

7 TECHNICAL DATA 12/150, 24/75, 24/100, 48/50 & 3-24/100

Function apparatus	battery charger/rectifier
Manufacturer	Mastervolt, Amsterdam

INPUT	12/150	24/75	24/100	48/50	3-24/100
Mains voltage	230V, -10% + 15% or 117V, -10% + 15%				3x 400V
Frequency	50-60 Hz \pm 5 Hz				
Inrush current	none, the battery charger is equipped with a soft start in accordance with IEC 1003-3				
Current	12A	12A (24A)**	16A (32A)**	16A (32A)**	6.5A
Power factor (Cos phi)	1	1	1	1	\approx 0.8
Efficiency	89%	89%	89%	89%	89%
Input power	2700W	2700W	3600W	3600W	3500W

OUTPUT	12/150	24/75	24/100	48/50	3-24/100
Nominal voltage	12V DC	24V DC	24V DC	48V DC	24V DC
Charge current	150A	75A	100A	50A	100A
Outputs	1x150A	1x75A	1x100A	1x50A	1x 100A
Charge characteristic	three-step, fully automatic				
Kind of batteries	open and closed lead acid (gel or wet)				
Charge voltages at 25°C*					
• absorption	14.25V	28.5V	28.5V	57V	28.5V
• float	13.25V	26.5V	26.5V	53V	26.5V
Voltage ripple	max. 100mV RMS with resistive load @ full power				
Short circuit current (1/4 of max.)	37.5A	18.75A	25A	12.5A	25A
Cable size (within 3 mtrs)	50 mm ²	35 mm ²	35 mm ²	25 mm ²	35 mm ²
Charger fuse (external)	160A	80A	100A	50A	100A

ENVIRONMENTAL

Ambient temperature	-20 to 40°C @ 100% output power, derated with 2,5% / °C 40°C
Cooling	forced air, by means of a ventilator with variable speed
Humidity	maximum 95% RV non condensing

ENCLOSURE (TYPE C3)

Dimensions (hwxwd) mm	420x318x144	420x318x144	420x318x144	420x318x144	420x318x144
Protection degree	IP23	IP23	IP23	IP23	IP23
Weight	9 kg	9 kg	9 kg	9 kg	10 kg
Safety	IEC 335-2-29				
EMC emission	EN 50081-1				
EMC immunity	EN 50082-1				

* Depending on charge status and battery condition.

** At 117V mains voltage.

8 EC DECLARATION OF CONFORMITY



Manufacturer: Mastervolt
Address: Snijdersbergweg 93
1105 AN AMSTERDAM
The Netherlands

Herewith declares that:

Product: MASS battery charger
Model: MASS 12/60-2 MASS 24/75
 MASS 12/80-2 MASS 24/100
 MASS 12/150 MASS 48/25
 MASS 24/50-2 MASS 48/50
 MASS 3-24/100

Is in conformity with the provision of the EC EMC directive 89/336/EEC and amendments 92/31/EEC and 93/68/EEC.

The following harmonized standards have been applied:

Generic emission standard	EN 50081-1:1992
Generic immunity standard	EN 50082-1:1992
Low voltage directive 73/72/EC	EN 60335-1:1999
	EN 60335-2-29:1996

Amsterdam,

A handwritten signature in black ink, appearing to be 'F.J. ter Heide', written over a light blue horizontal line.

Dr. F.J. ter Heide,
Managing director Mastervolt



MASTERVOLT

Snijdersbergweg 93, 1105 AN Amsterdam, The Netherlands

Tel.: INT+ 31-20-3422100

Fax: INT+ 31-20-6971006

www.mastervolt.com

APPENDIX A, B & C

**MASS 12/60-2; 12/80-2; 12/150; 24/50-2; 24/75
24/100; 48/25; 48/50; 3-24/100**

battery charger



TECHNICAL DATA

FOR 12V CHARGERS, models: 12/60-2, 12/80-2 & 12/150

	Set points register	Setpoint
1	Min. bulk time	30 sec.
2	Temperature variation	-30 mV/C
3	Return to bulk time	30 sec.
4	Return to bulk voltage	12.80 V
5	Max. bulk/abs time	360 min.
6	Min. abs time	15 min.
7	Return Amps	2.5 Amps
8	Max. charge current	I max
9	Bulk voltage	14.25 V
10	Abs voltage	14.25 V
11	Float voltage	13.25 V
12	Forced to float voltage	13.25 V
13	Gel voltage setting	550 mV
14	Diode compensation setting	600 mV
15	DC high alarm on	16.00 V
16	DC high alarm off	15.00 V
17	DC low alarm on	10.00 V
18	DC low alarm off	11.00 V
19	Alarm delay time	30 sec.

FOR 24V CHARGERS, models: 24/50-2, 24/75, 24/100 & 3-24/100

	Set points register	Setpoint
1	Min. bulk time	30 sec.
2	Temperature variation	-60 mV/C
3	Return to bulk time	30 sec.
4	Return to bulk voltage	25.6 V
5	Max. bulk/abs time	360 min.
6	Min. abs time	15 min.
7	Return Amps	2.5 Amps
8	Max. charge current	I max
9	Bulk voltage	28.5 V
10	Abs voltage	28.5 V
11	Float voltage	26.5 V
12	Forced to float voltage	26.5 V
13	Gel voltage setting	1100 mV
14	Diode compensation setting	600 mV
15	DC high alarm on	32 V
16	DC high alarm off	30 V
17	DC low alarm on	20 V
18	DC low alarm off	22 V
19	Alarm delay time	30 sec.

FOR 48V CHARGERS, models: 48/25 & 48/50

	Set points register	Setpoint
1	Min. bulk time	30 sec.
2	Temperature variation	-120 mV/C
3	Return to bulk time	30 sec.
4	Return to bulk voltage	51.2 V
5	Max. bulk/abs time	360 min.
6	Min. abs time	15 min.
7	Return Amps	2.5 Amps
8	Max. charge current	I max
9	Bulk voltage	57 V
10	Abs voltage	57 V
11	Float voltage	53 V
12	Forced to float voltage	53 V
13	Gel voltage setting	2200 mV
14	Diode compensation setting	600 mV
15	DC high alarm on	64 V
16	DC high alarm off	60 V
17	DC low alarm on	40 V
18	DC low alarm off	44 V
19	Alarm delay time	30 sec.

DIMENSIONS FOR 12/60-2, 12/80-2, 24/50-2 & 48/25

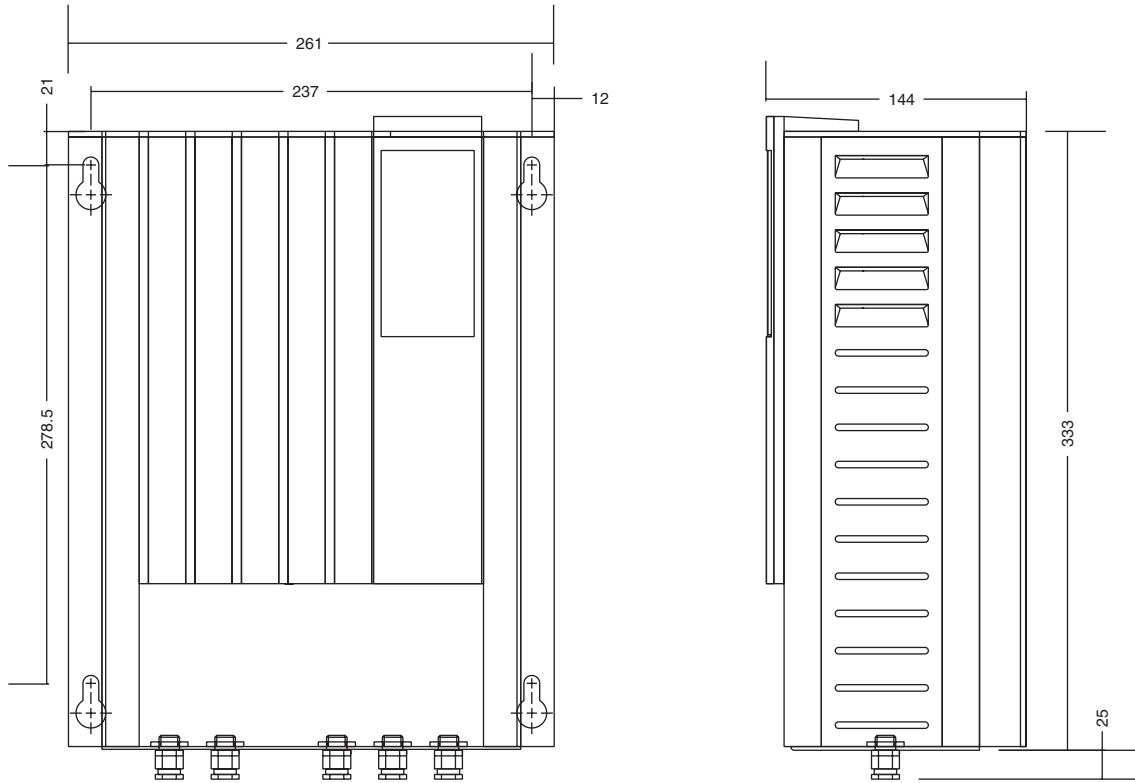

Mass C2 enclosure.

DIMENSIONS FOR 12/150, 24/75, 24/100, 48/50 & 3-24/100

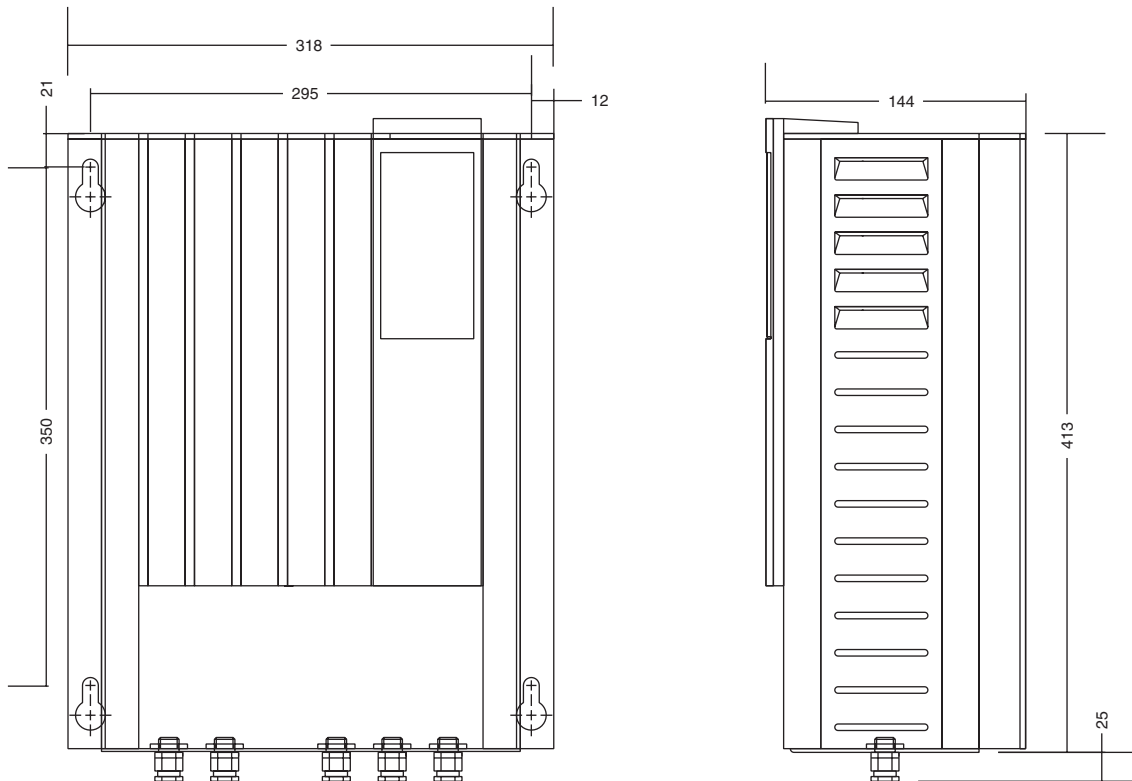

Mass C3 enclosure.

panel code	C-4-RB
part number	07-04-04100

MASTERVISION MODULAR SWITCHBOARDS

CAUTION



1. Lethal voltages exist on your vessel. Make sure all shore power, onboard generating sources and batteries are disconnected before beginning installation of your electrical panel.
2. AC modules will have lethal voltages on the bus bars and terminals. The coating on these bars is for identification only and should not be relied on as an insulator. Additional safety enclosures may be required in some installations.
3. Make sure all AC modules are bonded to the ship's AC ground bus. When grouping modules together to form your panel, a single ground may be used. Use a resistance meter to verify ground to all modules.

SPECIFICATIONS

description: type:	remote basic charger control for Mass & IVO smart chargers
dimensions panel (wxh): panel depth:	60 x 65 mm 40 mm

The basic remote panel

The basic remote panel is a useful power device for remote control of the Mass an Ivo smart Mastervolt battery chargers. The basic remote control does indicate the status of the charge control by six high power leds.

The remote control is easy to install by a plug-in standard twisted six pole RJ45 telephone plug between the analog output of the charger and the panel. The communication of the remote control and charger is based on analog technology. The remote panel can be used as an interface for a custom made panel or for a dual remote indicator.

The basic remote panel has a combined CSI-DC/alarm (csi=charger status interface).

The potential free change-over contacts indicate if the charger is ON or in general failure. The DC alarm set points can be adjusted in the chargers by use of the adjustment interface.

Specifications

Remote cable:	
Connector	RJ45, 6 pole, male
Max length	6 meter, max
Type	reversed wire
External led drive:	
I _{max}	5 mA
U _{max}	2,5V
General CSI alarm	
Max rating	1 Amp, 30 VDC
NC-on	When the charger is off or the charger is in failure, the normally closed contact is closed
C	Common
NO-on	When the charger is on and no-failure is indicated the normally open contact is closed
Connectors	0,75 mm2

These products fully comply to the latest CE standards in force from January 1st 1996 and are produced to ISO 9001 standards.

ISO 9001

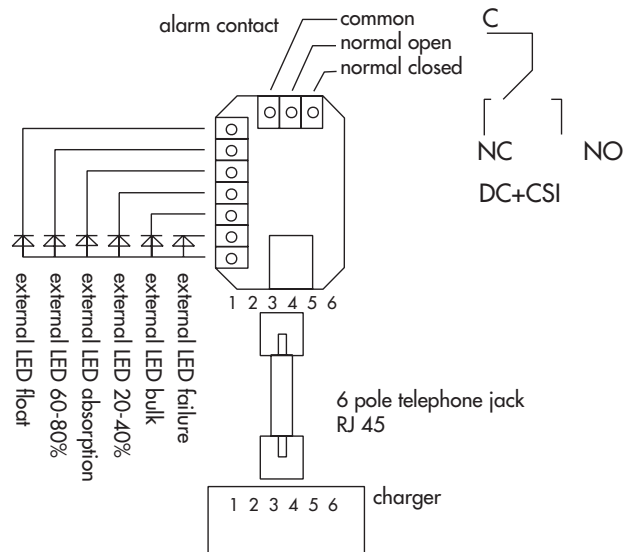
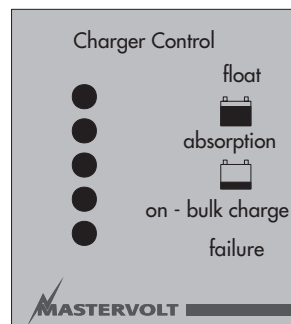

Combined CSI failure and DC high/low alarm

Bat TC failure	Battery temperature sensor out of range <20°C & >60°C
Voltage sense failure	Voltage sense out of range >3 VDC
Sys. temp. failure	Charger is out of temperature range (overload) (>75--85 °C)
Short break indicator	Charger in reduced current mode (short break mode) U _{out} <.5VDC

DC alarm

Battery range out of range (with standard setting of charger)

	12V	24V	
DC low on	10.0	20.0	VDC
DC low off	11.0	22.0	VDC
DC high on	16.0	32.0	VDC
DC high off	15.0	30.0	VDC
Delay time	30	30	SEC

panel code	C-3-RS
part number	07-04-03040

MASTERVISION MODULAR SWITCHBOARDS

CAUTION



- Lethal voltages exist on your vessel. Make sure all shore power, onboard generating sources and batteries are disconnected before beginning installation of your electrical panel.
- AC modules will have lethal voltages on the bus bars and terminals. The coating on these bars is for identification only and should not be relied on as an insulator. Additional safety enclosures may be required in some installations.
- Make sure all AC modules are bonded to the ship's AC ground bus. When grouping modules together to form your panel, a single ground may be used. Use a resistance meter to verify ground to all modules.

SPECIFICATIONS

description: type:	remote standard charger control for Mass & IVO smart chargers
dimensions panel (wxh): panel depth:	120 x 65 mm 40 mm

The standard remote panel

The standard remote panel is a useful power device for remote control of the Mass an IVO smart Mastervolt battery chargers. The standard remote control does indicate the status of the charge control by six high power leds and control the output current by setting the potential meter. The remote control is easy to install by a plug-in standard twisted six pole RJ45 telephone plug between the digital rs232 output of the charger and the panel. The serial communication of the remote control and the charger is based on rs232 technology. The remote panel can be used as an interface for a custom made panel or for a dual remote indicator. The standard remote panel has a CSI (csi=charger status interface) and a DC high/low alarm. The two potential free change-over contacts indicate if the charger is ON or in general failure. The DC alarm set points can be adjusted in the charger by use of the adjustment interface.

Specifications

Remote cable:	
Connector	RJ45, 6 pole, male
Max length	6 meter, max reversed wire
Type	
External led drive:	
I _{max}	5 mA
U _{max}	2,5V
External current control	
R pot cc	0..1kOhm 0..100%
General CSI alarm	
Max rating	1 Amp, 30 VDC
NC-on	When the charger is off or the charger is in failure, the normally closed contact is closed
C	Common
NO-on	When the charger is on and no-failure is indicated the normally open contact is closed
DC-high/low alarm (combined function with CSI)	
Max rating	1 Amp, 30 VDC
NC-on	When there is no DC failure, the normally closed contact is closed
C	Common
NO-on	When there is a DC failure the normally open contact is closed
Connectors	0,75 mm ²

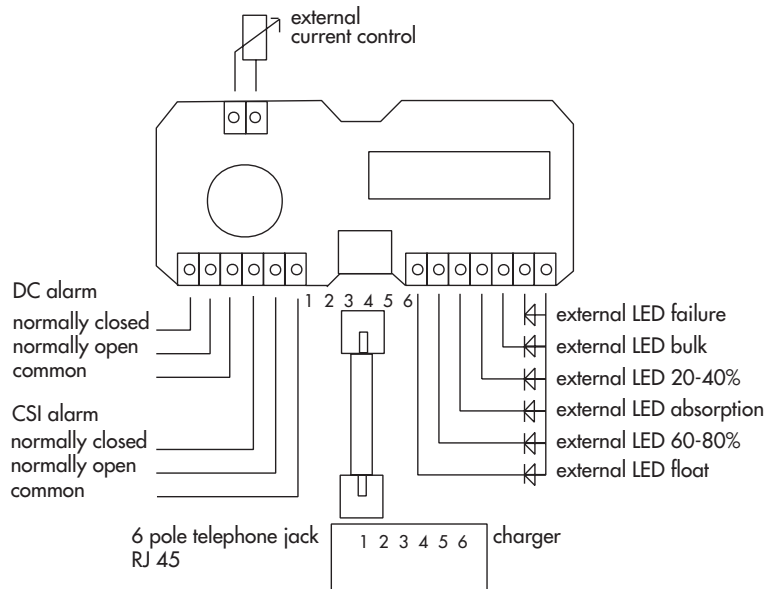
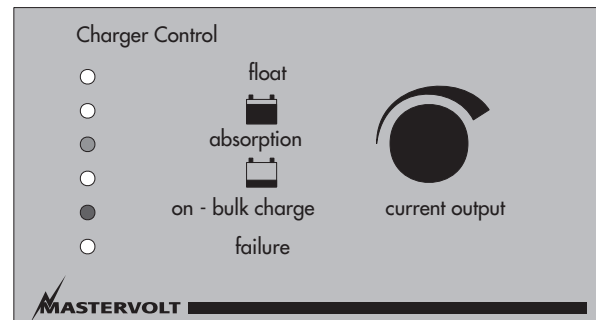

CSI failure

Bat TC failure
Voltage sense failure
Sys. temp. failure
Short break indicator

Battery temperature sensor out of range <20°C & >60°C
Voltage sense out of range >3 VDC
Charger is out of temperature range "overload" (>75--85 °C)
Charger in reduced current mode (short break mode)
U_{out} <4..5VDC

DC alarm

Battery range out of range (with standard setting of charger)

	12V	24V	
DC low on	10.0	20.0	VDC
DC low off	11.0	22.0	VDC
DC high on	16.0	32.0	VDC
DC high off	15.0	30.0	VDC
Delay time	30	30	SEC

STANDARD INSTALLATION EXAMPLE

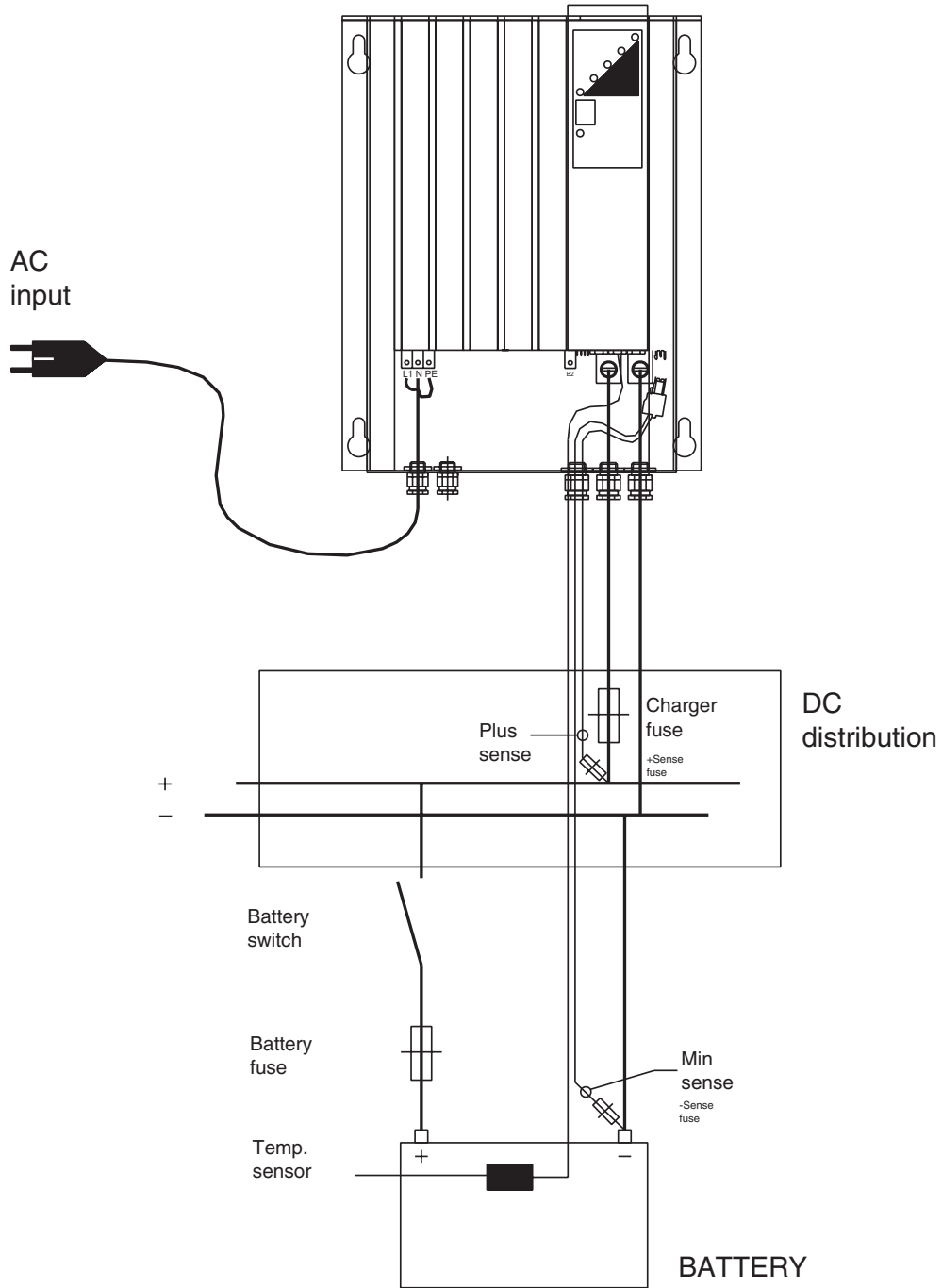

Battery sense connections:
 -S to the Minus of the battery
 +S to the battery side of the Charger fuse

INSTALLATION WITH BATTERY ISOLATOR EXAMPLE

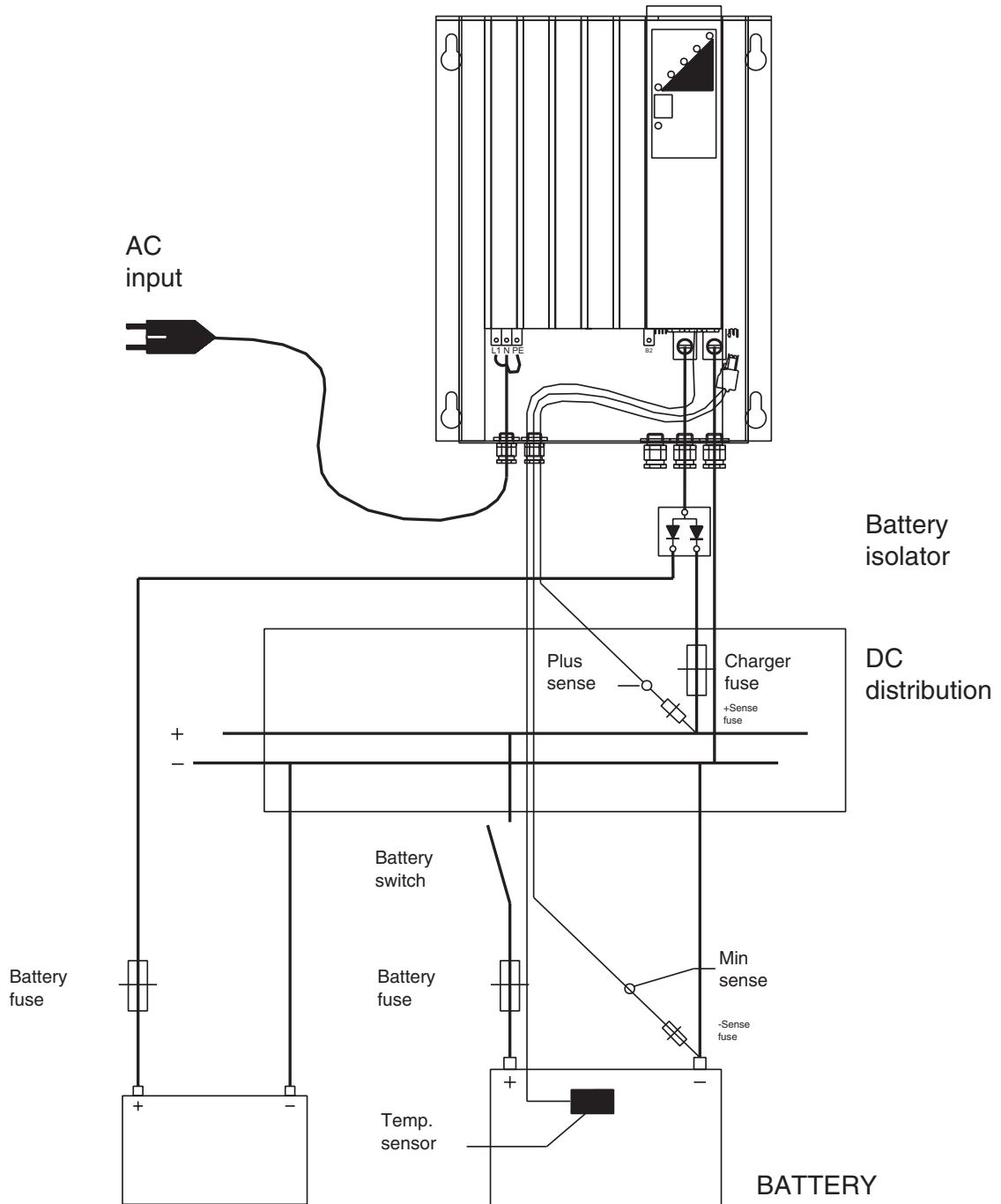

Battery sense connections:

-S to the Minus of the battery

+S to the battery side of the Battery Isolator

NOTE: when using the sense connection do NOT use the DIP switch setting



MASTERVOLT

Snijdersbergweg 93, 1105 AN Amsterdam, The Netherlands

Tel.: INT+ 31-20-3422100

Fax: INT+ 31-20-6971006

www.mastervolt.com