



# Hobby 2011



| VAN



| SIESTA



| SIESTA EXCLUSIVE



| TOSKANA



| TOSKANA EXCLUSIVE



| SPHINX





## *Hobby – always a good decision*

Exciting natural landscapes, foreign cities and places, people – making new friends – the best way to experience this is to go on holiday in a motorhome.

Motorhomes have been made in northern Germany for over 40 years. Our experience in development and production is evident in every Hobby motorhome. Our goal is to implement the right ideas in a contemporary and optimal technical manner, thus turning mobile travelling into a relaxing holiday treat. Hobby motorhomes are also characterised by their distinctive design. Whether it's their elegantly curved exterior walls or individual design details, a Hobby is and will remain one thing: unmistakable!



Harald Striewski  
Owner

Are you a globetrotter? A family holiday by the beach or city breaks for two? Our various model series and layouts are just as individual as your holiday expectations. The deciding factor is what you like! Take your time and choose your new motorhome at your own leisure.

What is really important to you on holiday? How big should the kitchen be? Do you prefer to sleep over-cab or in a cosy double bed? Do you need a spacious garage at the rear for your bikes?

Every one of our models offers practical solutions for your personal needs.

Choose a Hobby motorhome.

Yours sincerely



## SAFETY ✓

We carry out regular testing of our motorhomes on the automotive industry's most demanding test tracks. During these tests, the vehicles are subjected to extreme strains, so that you can always enjoy your holidays without a care in the world. The safety of our motorhomes is a key priority at Hobby.



## FITTINGS & DESIGN ✓

We have set the benchmark in terms of fittings and design for many years in the leisure vehicle sector. Hobby offers far more fittings as standard than many other manufacturers. The great success of Hobby motorhomes however can be attributed to their exclusive design. A Hobby has been voted „Motorhome of the Year“ over 20 times.



## QUALITY ✓

Quality is a key component of Hobby's corporate philosophy. Our management system is certified to the latest ISO 9001:2008 standards. The quality of our vehicles is constantly monitored and documented at fixed production stations. Only when all quality checks have been successfully passed are Hobby motorhomes made available to the public.

# ARGUMENTS

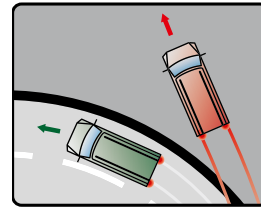

ABS (anti-lock braking system)

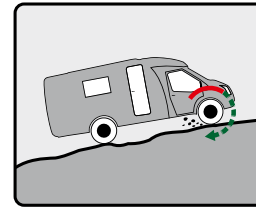

ASR (anti-slip control)

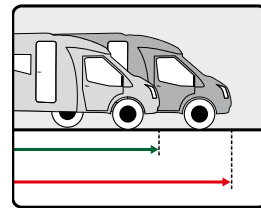

Brake assistant

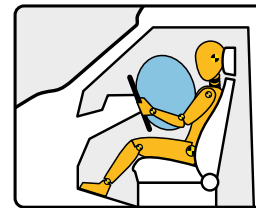

Airbags

Safety systems shown are model-specific and are not available for all basic vehicles.

## TECHNOLOGY & SAFETY

Many safety features that you will know from car construction can be found as standard in our vehicles. An anti-locking brake system (ABS) means the motorhome remains fully controllable in the most difficult situations. Many other safety features, e.g. airbags, electronic immobiliser, ASR or traction control, central locking and extended exterior mirrors give you the kind of safety you need for long tours.

## BASE VEHICLES

When manufacturing our motor homes, we rely on three tried-and-tested chassis manufacturers: Ford, Fiat and Iveco. With its reliable modern engines, Ford is perfect for our compact models. Customers looking for a more exclusive option will be delighted with the impressive driving dynamics and individual design of the Fiat Ducato models. For our luxury class we use superior, quiet-running Iveco vehicles.

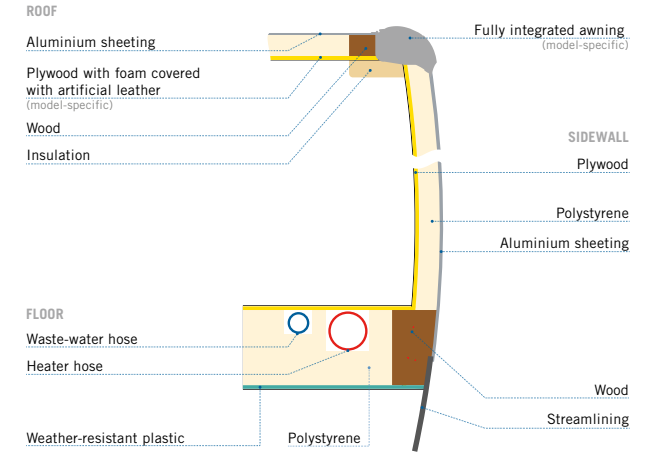

Cross-section: floor/sidewall of the Toskana/Toskana Exclusive range

## WINTER SUITABILITY

Hobby vehicles are particularly popular in Scandinavian countries, and with good reason. With their sidewalls and roof made of 34-mm-thick highly insular sandwich elements, and Webasto Thermo Top C parking heating, which keeps the driver's cabin pleasantly warm via the vehicle fans, they make winter caravanning a delight. (Optional extra)



## LIGHT AND ECONOMIC

One of our designers' key objectives is to save weight without compromising on comfort. New driving license regulations mean the 3.5-ton class is now more appealing than ever. By intelligently lengthening the frame alone, we have been able to cut weight depending on the vehicle type by up to 23 kg. The targeted use of lightweight construction materials has brought further weight benefits. Less weight helps reduce the fuel consumption of our vehicles.

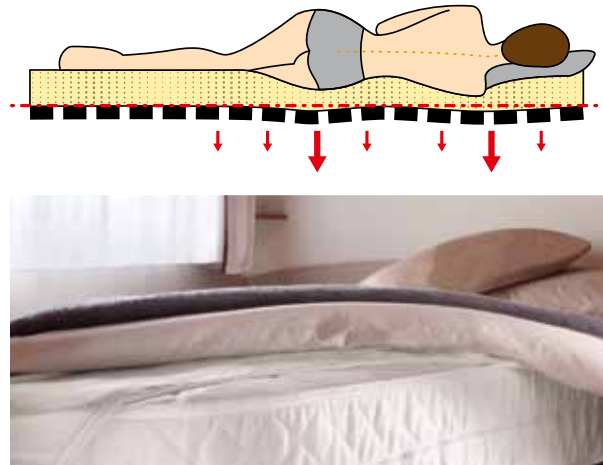

## SLEEPING COMFORT

After a long day's touring, nothing is more important than a restful night's sleep – try it for yourself. Hobby slatted frame systems made of flexible multi-layered beech wood offer the kind of sleeping comfort you enjoy at home. The mattresses are also of a very high quality: sprung and cold foam mattresses provide everything you need for the sweetest of dreams. Anyone looking for a little extra comfort can also choose the ergonomically optimised FROLI bed system.



## ERGONOMICS

Hobby vehicles offer quality you can feel. Ergonomics is the key consideration when designing our handles, seats and step treads. Sturdy handles that fit comfortably in the hand make day-to-day work much easier. The new air-sprung, height-adjustable pilot seats, available as an option, make travelling more comfortable and kinder on the body. An electrically retracting step, meanwhile, makes entering and leaving the vehicle a pleasure.

# ARGUMENTS



## INNOVATIONS

Innovative thinking is the key to success. Many innovations in the caravanning sector can be traced back to Hobby. The lightly curved exterior walls are legendary, and are what give Hobby Exclusive models their elegant style. The use of newly developed water filters is also particularly innovative. One optional extra that is appreciated by experienced motorhome enthusiasts is a fully integrated awning.

## AWARDS

The success of Hobby motorhomes is not just a result of their excellent price-performance ratio – it also comes down to constant investments made in quality and development.

Readers of specialist magazine promobil selected Hobby for the motorhome of the year award over 20 times. In 2008, Reisemobil International magazine carried out a major customer survey of motorhome owners, which saw our motorhomes pick up the

Customer King Award in the price/performance, design and workshop categories. We are particular proud of the Golden Steering Wheel that we won for our T 600 GFS.

One of our greatest compliments was paid by British magazine Which motorcaravan: during a comparative test of competitor vehicles, the magazine declared the Hobby VAN tested “simply the best”. Hobby says thank-you.

### Legal note

Due to the wide number of different Hobby ranges and models, it is not possible to differentiate between features in the Arguments section. We would like to point out that some arguments relate to optional extras and that not all features are available for every model. As such, the arguments outlined are not to be taken as guaranteed product features. Thank you for your understanding.

## On-board technology

Are you looking for more independence – including from external energy sources? You can have exactly that with the additional premium gel battery, offering 80 Ah.

Used only by Hobby in the caravan sector, the 'IBScontrol' battery sensor from Hella ensures your battery will never shut down unexpectedly. A colour display shows how much energy is remaining.

Fitted as standard, a high-performance 3M water filter ensures the highest quality drinking water, while a premium pump offers the same water pressure as at home.

All energy-consuming systems can be easily controlled via the practical operating panel.

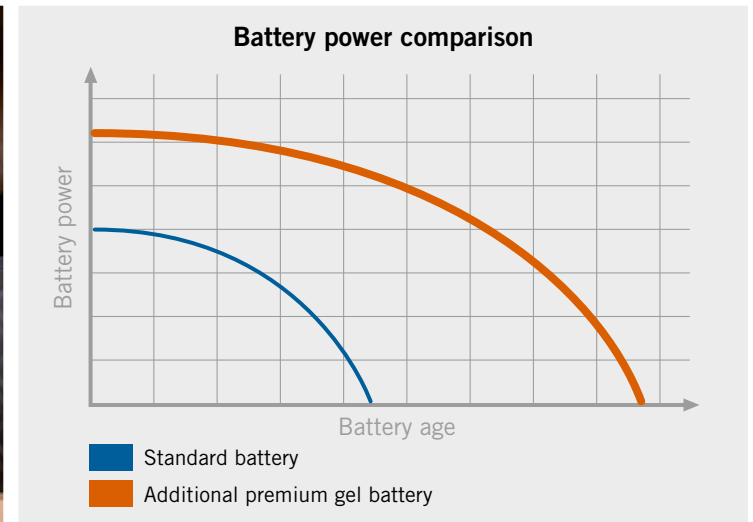



# DRIVING PLEASURE

## *Travel comfort*

There are many ways to enjoy a little extra comfort when on the road ... and Hobby can show you them!

With Goldschmitt air suspension, you'll feel as if you're travelling on a cloud. The multimedia navigation device from Eclipse features a removable TOMTOM 4.3" navigation unit and additional video system for reversing, offering a clear view at all times and maximum driving safety. The sun blind integrates perfectly into the vehicle and remains free of dirt and rainwater.

The interior lights are easily operated via the new operating panel. Would you prefer a bright light to work under or a cosy evening mood? You decide with our optional LED lighting package, which also allows you to make energy savings. Have a good trip!



Goldschmitt air suspension



Reversing camera including navigation device

## Burn time with identical energy consumption:



Four LED spots



Two halogen spots



Sun blind, fully integrated

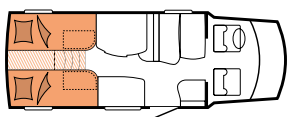

VAN EXCLUSIVE TL 500 GESC

Long beds in the rear

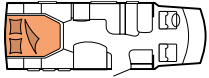

TOSKANA EXCLUSIVE D 690 GQSC

Island bed



SIESTA T 600 AK KM

Drop down bed

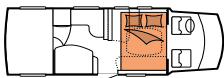

TOSKANA EXCLUSIVE D 690 H GFLC

Drop down bed

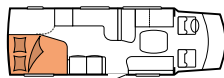

TOSKANA EXCLUSIVE D 750 FLC

Fixed bed, lengthwise

# SLEEPING

## *Cosy and comfortable*

An appropriate, peaceful place to relax at any time. Would you rather climb to a cosy over-cab bed in the Hobby Motorhome?

The French drop down bed saves space while being very comfortable. It can be stowed away under the roof of the vehicle with just a push of a button.

Whatever your preference, you'll find the perfect space for sweet dreams here!



Fixed bed steps



Bed ladder (fold-away, model-specific)



SIESTA T 600 AK KM

Children's bunk bed

# SLEEPING



Slatted frame including sprung mattress



Comfortable Bed System with Special Foam Mattress

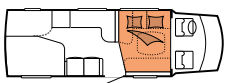

TOSKANA EXCLUSIVE D 750 FLC

Converted seating area



VAN EXCLUSIVE T 500 GFSC

Shower cubicle

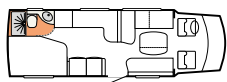

TOSKANA EXCLUSIVE D 750 FLC

Shower

# WASHROOM

## *Refreshingly innovative*

Our innovative washroom options in a Hobby motorhome are also just as unique as your holiday. From a compact round shower cubicle to a larger washroom at the rear with a separate shower cubicle.

The different options provide a choice of facilities for everyone – whether in the morning, after lunch or at night. Decide for yourself how much wash-room you want!

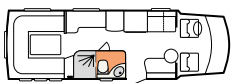

TOSKANA EXCLUSIVE D 750 H UCC

Washroom with separate shower

Compact? Yes!  
Cramped? Never!

Our baths fit perfectly in the layout of your Hobby vehicle. Thanks to the intelligent division of space, you have the freedom of movement you need at all times. Everything is positioned in the ideal location, with our refreshing designs!

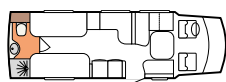

TOSKANA EXCLUSIVE D 750 ELC

End washroom



# WASHROOM



Tab



Shower fittings



VAN T 500 FSC

Large side kitchen

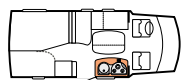

TOSKANA D 600 FL

side kitchen



SIESTA EXCLUSIVE T 600 FC

corner kitchen

# COOKING

## *Three stars for the kitchen*

Would you like to enjoy a quick snack or an elegant dinner at your destination? What is important to you while you are travelling?

The fully-equipped, modern holiday kitchens provide all the options that you need when cooking during your holiday.

The fixed, high quality work surfaces are fully integrated into the large corner kitchen providing plenty of space; the side kitchen can be integrated into the different layouts practically and elegantly.

You can be sure of one thing: your guests will love it!



TOSKANA EXCLUSIVE D 750 ELC

Large corner kitchen



High-quality work surface with stainless steel hob/sink combination and glass cover

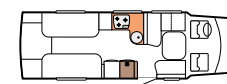

TOSKANA EXCLUSIVE D 750 ELC  
THETFORD hob

# COOKING



Ravioli is the favourite dish of caravan enthusiasts? Those days are long gone! Our THETFORD professional kitchen meets the needs of the most demanding chefs. Using the high-performance three-burner hob, complex dishes can be easily prepared for larger groups of friends.

And for fresh ingredients, there's always the right fridge-freezer combination: 112 litres of storage space is perfect for couples, while 150 litres is sufficient for the whole family. New and exclusive to Hobby, we now also offer the space-saving Slim Tower, with a 140-litre capacity and removable ice box.

Bon appétit!

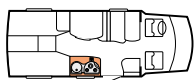

TOSKANA D 650 ESC  
Small, 112 litre refrigerator

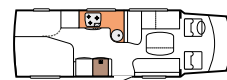

TOSKANA EXCLUSIVE D 750 FLC  
Large, 150 litre refrigerator

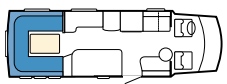

TOSKANA EXCLUSIVE D 750 H UCC

Circular seating unit in the rear

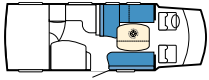

TOSKANA EXCLUSIVE D 690 GFLC

Large wraparound seating area

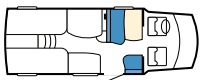

VAN EXCLUSIVE DL 500 GESC

Compact seating unit

# LIVING

## *A living room with vision*

Where would you like to sit? What would you like to see? Our living ideas have a little something for everyone in mind. Enjoy the morning's first cup of coffee whilst enjoying the view of the valley from the swivelling seats. This way, you will soon come up with the right plans for the new day. In the evening, after a day full of adventures, enjoy the sunset in peace with the whole family. Flexible daytime options that can be integrated practically and elegantly into the different layouts are the focus of the holiday for everyone.

Whether travelling alone, just the two of you or with the whole family travelling in the seats behind the cab offers the best views. Enjoy the selection.



High-quality wardrobe

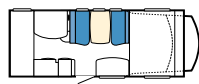

SIESTA T 600 AK KM

'Dinette' seating unit with optional additional seatbelt anchorage



# LIVING



Blind



Table with chrome trim



Shoe compartment



Warm airflow

The generous proportions of Hobby motor homes are immediately recognisable. When taking a closer look at the vehicle, the elegant, well-thought-out details are evident, such as the high-quality wardrobe and the elegant chrome trim around the edge of the table.

Practical features include our additional seatbelt anchorages, which allow up to six passengers to reach the destination safely. And sophisticated furniture units – warm air rises behind them, ensuring it is well distributed, and creating the optimum room temperature.



Bar in entrance area  
(model-specific)



Lighting elements  
(model-specific)



Roof light in the driver's cab  
(model-specific)

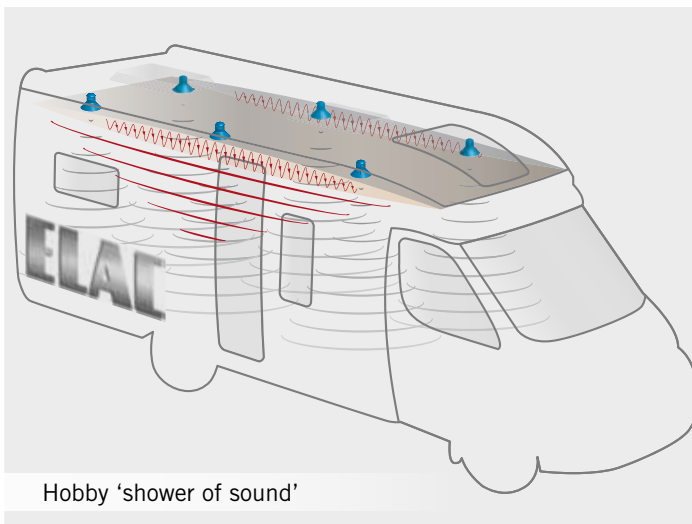
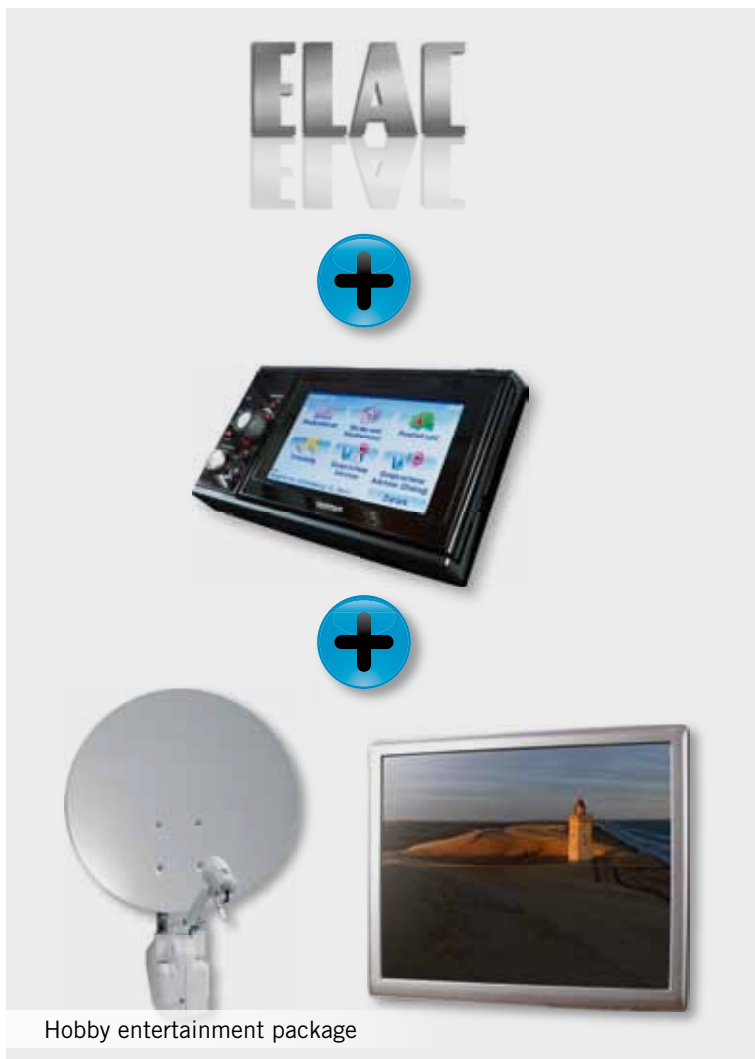

Do you like it light? The roof window in the driver's cab means you can also enjoy the summer sun while driving. In the evening, a host of lighting elements are available from spots to indirect lights.

On request, your Hobby motor home can even be transformed into a genuine multimedia centre: with a 19" flat screen, satellite dish, Eclipse multimedia navigation system and the exclusive ELAC speaker system, the ultimate in entertainment is guaranteed. Your favourite music sounds as if it has been conjured up live: the sophisticated ELAC system creates a 'shower of sound' in your motor home. A precisely balanced musical network, hidden above the roof lining, provides rich hi-fi tones.

High-end systems, made in Germany.

# MODEL SERIES



## VAN



The Hobby Van. One for all.



## VAN EXCLUSIVE



The perfect entry into the world of mobile holidays.



## VAN EXCLUSIVE DL



The Hobby Van Exclusive DL. The perfect entry into the world of mobile holidays.

30



## SIESTA



The Hobby Siesta. The versatile family friend.



## SIESTA EXCLUSIVE



The Hobby Siesta Exclusive. The sporty, elegant travel companion.

42



## TOSKANA



The Hobby Toskana. Comfortable and proven – a holiday classic.



## TOSKANA EXCLUSIVE



The Hobby Toskana Exclusive. Individual and dynamic – an extraordinary holiday experience.

50

## *Each one is in a league of its own*

Love mobility and want to feel that you don't have to compromise on anything even when you are travelling?

Good handling, lots of driving pleasure, generous space and the tried-and-tested performance of the three classic chassis from Ford, Fiat and Iveco make every model a perfect motorhome!

You will find many different layout concepts in the low profile models Hobby Van, Siesta Exclusive, Toskana and Toskana Exclusive. Each model series has its own distinctive style. Whether it is everyday or just on holiday – you will sense the unrestricted mobility here immediately.

The layouts of our over-cab Siesta and Sphinx models provide a generous amount of space. The cosy „sleeping area“ above the cab comfortably separates the living and sleeping areas.

Our luxury Sphinx models provide an extra helping of space and are a superior companion for your holiday.

Every Hobby motorhome provides ultimate holiday experiences at fair prices. Whether you are on the road with the economic Hobby Van Classic, suitable for everyday use, or discover the world in the elegant Hobby Toskana Exclusive – your personal taste decides.



**SPHINX**

**IVECO**

The Hobby Sphinx. The luxury over-cab motorhome with a timeless design

60

VAN





*Goodbye routine, hello holiday.*

Do you need a little time away from the stresses and strains of everyday life now and again? Then simply put your key in the ignition and leave your routine behind.

The Van is the most affordable entry-level model among our

motorhomes, yet offers the kind of comfort you would not want to be without when on the road. Two basic layout varieties are available to choose from: the vehicle is available with or without garage, though always features the reliable Ford chassis. Let's go!

VAN

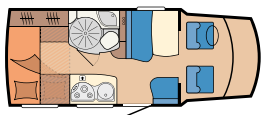

VAN T 500 FSC





Basic washroom



VAN T 500 FSC

Retractable bed

### Standard in all Van-Models:

- ABS (anti-lock braking system)
- ASR (anti-slip regulation)/traction control
- ESP (electronic stability programme)
- EBD (electronic brake force distribution)
- Driver's airbag
- Cruise control
- Power steering
- Electronic Immobiliser
- Remote-controlled central locking
- Electric window winders
- Extended exterior mirrors
- Swivelling driver and passenger seats
- Seatbelt anchorage with 3-point safety belts
- FORD audio system 6000 with CD player
- Double glazing, slightly tinted
- Painted front bumper
- Tyre repair kit
- Hazard triangle and first-aid kit
- Entry lights
- Dometic Seitz Mini-Heki 400 x 400 mm roof hood
- Retractable electric easy-access step
- Roof light in the driver's cab
- All windows hinged (except Roof light in the driver's cab)
- Cold-foam mattress
- Stainless steel sink with glass lid
- Stainless steel three-burner stove with glass lid
- DOMETIC fridge 96 l with 9 l removable ice box
- Clip for rubbish bag
- Glass cabinet
- THETFORD swivelling cassette toilet with electric flush
- Heated waste water tank
- TRUMA heating Combi 4
- 3M water filter
- Hot water supply in the kitchen and washroom
- High-pressure water pump
- Light operating panel
- 12 V/230 V power supply
- Gel battery, 80 Ah (habitation)
- Onboard control panel
- Additional spots
- Combi-cassette with blackout pleated fabric and insect protection
- 12-V/230-V power socket and aerial socket



Wooden decorative trim: Ariolo Birnbaum / Cappuccino

Upholstery: Lima

# Layouts

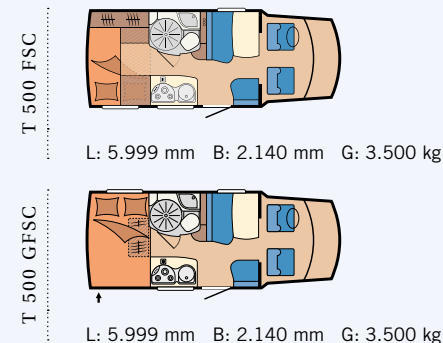

# VAN EXCLUSIVE





## *A stylish space-saving wonder*

Optimal use of space ensures that the Hobby Van Exclusive offers maximum freedom of movement. The comfortable single beds in the rear are perfect for unwinding after the most strenuous holiday experiences. Elegantly coordinated colours and a high-quality wood trim give the Hobby Van

Exclusive its own inimitable style. The timeless, individual exterior design with the impressive rear view makes choosing a Hobby Van Exclusive easy.

# VAN EXCLUSIVE

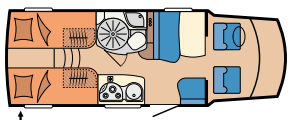

VAN EXCLUSIVE TL 500 GESC

# Layouts



Single beds



Kitchen

## Standard in all Van Exclusive-Models:

- ABS (anti-lock braking system)
- ASR (anti-slip regulation)
- ESP (electronic stability programme)
- EBD (electronic brake force distribution)
- Driver's airbag
- Cruise control
- Power steering
- Electronic Immobiliser
- Remote-controlled central locking
- Electric window winders
- Extended exterior mirrors
- Swivelling driver and passenger seats
- Seatbelt anchorage
- FORD audio system 6000 with CD player
- Double glazing, slightly tinted
- Painted front bumper
- Front mudflap
- Tyre repair kit
- Hazard triangle and first-aid kit
- Entry lights
- Dometic Seitz Mini-Heki 400 x 400 mm roof hood
- Retractable electric easy-access step
- Roof light in the pdriver's cab
- All windows hinged (except Roof light in the driver's cab)
- Cold-foam mattress
- Additional upholstery for emergency bed
- Folding bed extension
- Stainless steel sink with glass lid
- Stainless steel three-burner stove with glass lid
- DOMETIC fridge 96 l with 9 l removable ice box
- Clip for rubbish bag
- Glass cabinet
- THETFORD swivelling cassette toilet with electric flush
- Heated waste water tank
- TRUMA heating Combi 4
- 3M water filter
- Hot water supply in the kitchen and washroom
- High-pressure water pump
- Light operating panel
- 12 V/230 V power supply
- Onboard control panel
- Gel battery, 80 Ah (habitation)
- Additional spots
- Indirect lighting
- Combi-cassette with blackout pleated fabric and insect protection
- 12-V/230-V power socket and aerial socket

TL 500 GESC

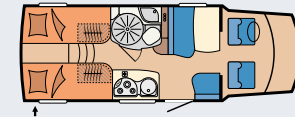

L: 6.750 mm B: 2.180 mm G: 3.500 kg



Wooden decorative trim: Ariolo Birnbaum / Cappuccino

Upholstery: Vulkano

# VAN EXCLUSIVE DL





*Italian for sophistication.*

Introducing the new Van Exclusive DL. Experience Italian-style holidays. Its sweeping exterior design offers the typical dynamism of the Van Exclusive models, while its powerful Fiat engine offers all the on-the-road power you need.

The Van Exclusive DL features single beds and a garage. And there are a host of other reasons why you should look south when selecting your next motorhome.

# VAN EXCLUSIVE DL

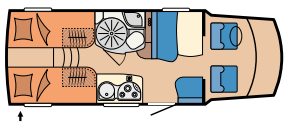

VAN EXCLUSIVE DL 500 GESC



# Layouts

## Standard in all Van Exclusive DL-Models:

- ABS (anti-lock braking system)
- ASR (anti-slip regulation)
- Driver's airbag
- Passenger airbag
- Cruise control
- Power steering
- Electronic Immobiliser
- Remote-controlled central locking
- Electric window winders
- Extended electrically adjustable heated exterior mirrors including radio antenna
- Swivelling driver and passenger seats
- Seatbelt anchorage
- CD radio including MP3
- Painted front bumper
- Front mudflap
- Tyre repair kit
- Hazard triangle and first-aid kit
- Entry lights
- Dometic Seitz Mini-Heki 400 x 400 mm roof hood
- Retractable electric easy-access step
- Roof light in the driver's cab
- All windows hinged (except Roof light in the driver's cab)
- Cold-foam mattress
- Additional upholstery for emergency bed
- Folding bed extension
- Stainless steel sink with glass lid
- Stainless steel three-burner stove with glass lid
- Clip for rubbish bag
- THETFORD swivelling cassette toilet with electric flush
- Heated waste water tank
- TRUMA heating Combi 4
- 3M water filter
- Hot water supply in the kitchen and washroom
- High-pressure water pump
- Light operating panel
- 12 V/230 V power supply
- Onboard control panel
- Gel battery, 80 Ah (habitation)
- Additional spots
- Indirect lighting
- Combi-cassette with blackout pleated fabric and insect protection
- 12-V/230-V power socket and aerial socket



Slim Tower (DL 550 GESC only)



Wardrobe beneath the bed



Wooden decorative trim:  
Ariolo Birnbaum / Cappuccino

Upholstery: Vulkano

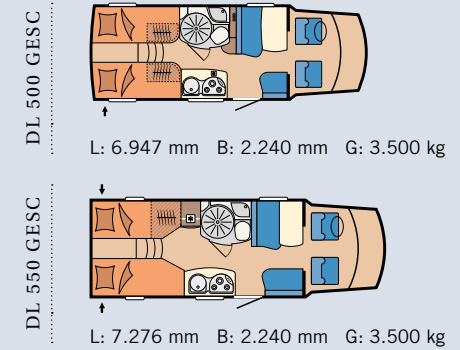

# SIESTA





*The versatile family friend.*

Straight exterior walls, an attractive, aerodynamic over cab, a pleasant one piece GRP back panel. The Hobby Siesta wins people over both inside and out with its classic design lines. Plenty of space for everything that needs to go with you on holiday can be found in the large storage

areas created by the practical layouts. Children are welcome! They will sleep well in the cosy over cab bed.

With reliable Ford technology, the Hobby Siesta is an ideal motorhome with lots of standard equipment at a competitive price. Good holidays are guaranteed!

# SIESTA

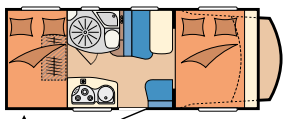

SIESTA T 555 AK GFSC

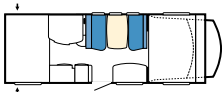

SIESTA T 650 AK GFM

'Dinette' seating unit

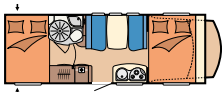

SIESTA T 650 AK GFM

**Standard in all Siesta-Models:**

- ABS (anti-lock braking system)
- ASR (anti-slip regulation)/traction control
- ESP (electronic stability programme)
- EBD (electronic brake force distribution)
- Driver's airbag
- Cruise control
- Power steering
- Electronic Immobiliser
- Remote-controlled central locking
- Electric window winders
- Extended exterior mirrors
- Seatbelt anchorage with 3-point safety belts
- FORD audio system 6000 with CD player
- Double glazing, slightly tinted
- Painted front bumper
- Front mudflap
- Tyre repair kit
- Hazard triangle and first-aid kit
- Entry lights
- Dometic Seitz Mini-Heki 400 x 400 mm roof hood
- Retractable electric easy-access step
- All windows hinged
- High-quality foam mattress (over-cab and children's beds)
- Stainless steel sink with glass lid
- Stainless steel three-burner stove with glass lid
- Clip for rubbish bag
- Glass cabinet
- THETFORD swivelling cassette toilet with electric flush
- Comfortable washroom
- Heated waste water tank
- TRUMA heating Combi 4
- 3M water filter
- Hot water supply in the kitchen and washroom
- High-pressure water pump
- Light operating panel
- 12 V/230 V power supply
- Gel battery, 80 Ah (habitation)
- Onboard control panel
- Additional spots
- Indirect lighting
- Combi-cassette with blackout pleated fabric and insect protection
- 12-V/230-V power socket and aerial socket



Wooden decorative trim: Ariolo Birnbaum / Cappuccino

Upholstery: Lima

# Layouts

T 555 AK GFSC

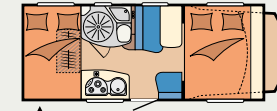

L: 5.999 mm B: 2.286 mm G: 3.500 kg

T 600 AK KM



L: 6.407 mm B: 2.286 mm G: 3.500 kg

T 650 AK GFM

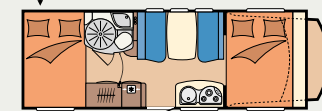

L: 6.923 mm B: 2.286 mm G: 3.500 kg

# SIESTA EXCLUSIVE





*Beautiful. Practical. Sporty.*

Look forward to every journey!  
Regardless of where you are  
travelling to and how long you are  
travelling for, you will always feel  
comfortable in the Hobby Siesta  
Exclusive.

The elegant interior design and  
the sporty, modern upholstery

combinations invite you to relax  
and unwind at any time.

The practical and beautiful furni-  
ture with lots of storage options  
provide plenty of space for small  
and large luggage items.

Have a good trip!

# SIESTA EXCLUSIVE

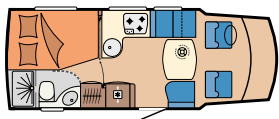

SIESTA EXCLUSIVE T 600 FC





SIESTA EXCLUSIVE T 650 FLC

Corner kitchen



SIESTA EXCLUSIVE T 650 FLC

**Standard in all Siesta Exclusive-Models:**

- ABS (anti-lock braking system)
- ASR (anti-slip regulation)/traction control
- ESP (electronic stability programme)
- EBD (electronic brake force distribution)
- Driver's airbag
- Cruise control
- Power steering
- Electronic Immobiliser
- Remote-controlled central locking
- Electric window winders
- Extended exterior mirrors
- Swivelling driver and passenger seats
- Seatbelt anchorage
- Seatbelt anchorage with 3-point safety belts
- Audio system 6000 with CD player
- Double glazing, slightly tinted
- Painted front bumper
- Front mudflap
- Tyre repair kit
- Hazard triangle and first-aid kit
- Entry lights
- Mini-Heki 400 x 400 mm roof hood
- Midi-Heki 700 x 500 mm roof hood
- Retractable electric easy-access step
- Roof light in the pdriver's cab
- All windows hinged (except Roof light in the driver's cab)
- Roof light in the driver's cab
- Sprung mattress
- Stainless steel sink with glass lid
- Stainless steel three-burner stove with glass lid
- DOMETIC fridge combination, fridge capacity 150 l with 26 l ice box Backofenelement
- Combi-cassette with blackout pleated fabric and insect protection
- Seperate shower
- Heated waste water tank
- TRUMA heating Combi 4
- 3M water filter
- Hot water supply in the kitchen and washroom
- High-pressure water pump
- Light operating panel
- 12 V/230 V power supply
- Gel battery, 80 Ah (habitation)
- Operating panel
- Additional spots
- Indirect lighting
- Bar in entrance area
- Combi-cassette with blackout pleated fabric and insect protection
- 12-V/230-V power socket and aerial socket



Wooden decorative trim: Ariolo Birnbaum / Cappuccino

Upholstery: Vulkano

# Layouts

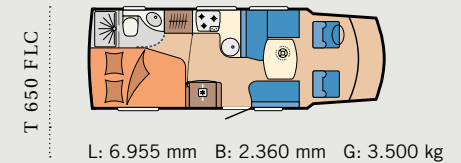
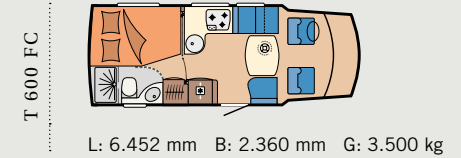

# TOSKANA





## *A winning concept*

You don't know what you will experience on your next holiday yet. But you know exactly what is important to you. Our interior design caters to the needs of individual motorhome holiday-makers. Perfectly coordinated wood design, atmospheric lighting

and winning layout solutions give your Hobby Toskana a personal style. The unique one piece GRP back panel dynamically draws on the classic shapes of the straight exterior walls.

A beautiful motorhome.

# TOSKANA

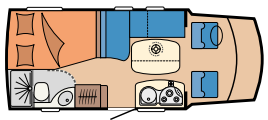

TOSKANA D 600 FL



TOSKANA D 600 FL

Seating unit

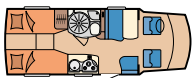

TOSKANA D 650 ESC

**Standard in all Toskana Models:**

- ABS (anti-lock braking system)
- ASR (anti-slip regulation)
- Driver's airbag
- Passenger airbag
- Cruise control
- Power steering
- Electronic Immobiliser
- Remote control central locking
- Electric window winders
- Extended exterior mirrors
- Extended electrically adjustable heated exterior mirrors including radio antenna
- Swivelling driver and passenger seats
- Seatbelt anchorage with 3-point safety belts
- CD radio including MP3
- Painted front bumper
- Front mudflap
- Tyre repair kit
- Hazard triangle and first-aid kit
- Entry lights
- Dometic Seitz Mini-Heki 400 x 400 mm roof hood
- Retractable electric easy-access step
- Roof light in the driver's cab
- All windows hinged (except Roof light in the driver's cab)
- Stainless steel sink with glass lid
- Stainless steel three-burner stove with glass lid
- Fridge
- THETFORD swivelling cassette toilet with electric flush
- Heated waste water tank
- TRUMA heating Combi 4
- 3M water filter
- Hot water supply in the kitchen and washroom
- High-pressure water pump
- Light operating panel
- 12 V/230 V power supply
- Onboard control panel
- Gel battery, 80 Ah (habitation)
- Additional spots
- Indirect lighting
- Combi-cassette with blackout pleated fabric and insect protection
- 12-V/230-V power socket and aerial socket



Wooden decorative trim: Ariolo Birnbaum / Cappuccino

Upholstery: Lima

# Layouts

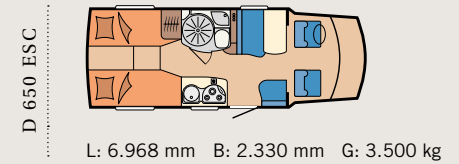
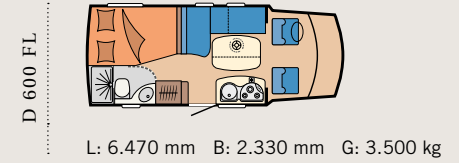

# TOSKANA EXCLUSIVE





*A motorhome for demanding people.*

The sweeping exterior walls and harmonious curves of the Toscana Exclusive generate holiday excitement in themselves. Though alongside the exclusive design,

this motorhome offers a host of other benefits. It delivers luxurious holidaying.

So what are you waiting for?

# TOSKANA EXCLUSIVE

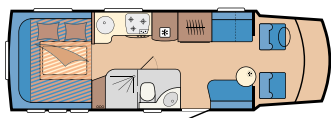

TOSKANA EXCLUSIVE H 750 H UCC



Lift-away bed fitted as standard with electric drive.



## *Heavenly levels of space!*

Do you love personal space? Then the new Toskana Exclusive with drop-down bed is exactly what you've been waiting for! At night, couples can doze to their hearts' content in the comfortable double bed, while during the day, their sleeping space disappears beneath the roof of the vehicle, maximising space to move around the interior.

Just a push of the button is all you need. The electronically adjustable mechanism, which changes easily between its sleeping height and daytime position, is included in all four layouts as standard.

Travel well. Sleep better.

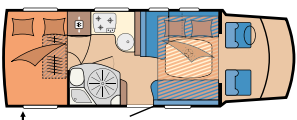

TOSKANA EXCLUSIVE D 690 H GFLC

# TOSKANA EXCLUSIVE



Framed window



TOSKANA EXCLUSIVE D 750 ELC

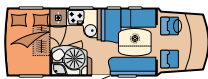

TOSKANA EXCLUSIVE D 690 GFLC

### Standard in all Toskana Exclusive-Models:

- ABS (anti-lock braking system)
- ASR (anti-slip regulation)
- Driver's airbag
- Passenger's airbag
- Cruise control
- Power steering
- Electronic Immobiliser
- Remote-controlled central locking
- Electric window winders
- Extended electrically adjustable heated exterior mirrors including radio antenna
- Extended exterior mirrors
- Swivelling driver and passenger seats
- Seatbelt anchorage with 3-point safety belts
- CD radio including MP3
- Painted front bumper
- Spare wheel
- Hazard triangle and first-aid kit
- Entry lights
- Dometic 400 x 400 mm roof hood
- Dometic 700 x 500 mm roof hood
- Retractable electric easy-access step
- Roof light in the driver's cab
- Framed window
- All windows hinged (except Roof light in the pdriver's cab)
- Roof rails
- Stainless steel sink with glass lid
- Stainless steel three-burner stove with glass lid
- DOMETIC Tec Tower fridge combination, fridge unit 150 l with 26 l TecTower ice box, oven unit (except 750 H UCC)
- THETFORD swivelling cassette toilet with electric flush
- Comfortable washroom
- 3M water filter
- Hot water supply in the kitchen and washroom
- High-pressure water pump
- Light operating panel
- 12 V/230 V power supply
- Gel battery, 80 Ah (habitation)
- Onboard control panel
- Additional spots
- Indirect lighting
- Combi-cassette with blackout pleated fabric and insect protection
- 12-V/230-V power socket and aerial socket



Wooden decorative trim: Ariolo Birnbaum / Cappuccino

Upholstery: Vulkano

# Layouts

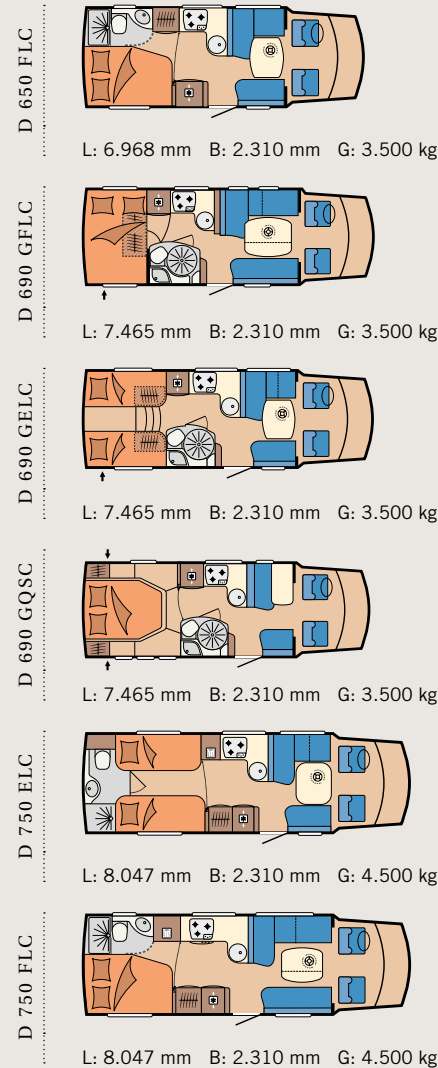

# Drop down bed models

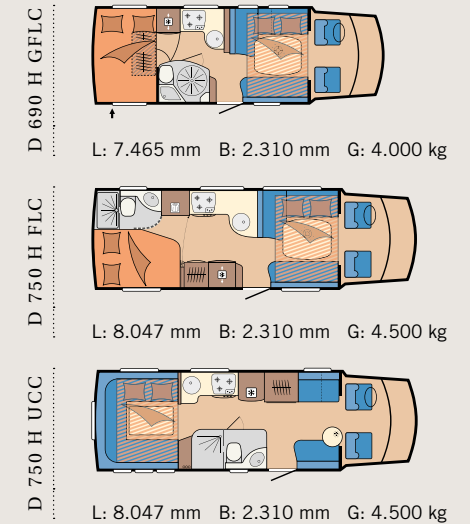

# SPHINX IVECO





*The luxury over-cab motorhome with a timeless design*

You enjoy extended holiday outings. You feel at home on the road. Then go on a long journey with the Hobby Sphinx. With its special equipment with a timeless design, the superior Iveco ride comfort and the space provided by our biggest over-cab motorhome, even long journeys

will become a unique holiday experience.

Take your family with you or discover the world as a couple! With the extra helping of space, travelling is twice as fun!

Goodbye!

# SPHINX IVECO



SPHINX I 770 AK GWMC



Over-cab bed

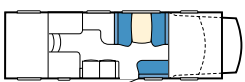

SPHINX I 770 AK GWMC

Seating area

### Standard in all Sphinx-Models:

- Diesel particle filter
- ESP (electronic stability programme)
- ABS (anti-lock braking system)
- AAS (hill start assist)
- ASR (anti-slip regulation)
- EBD (electronic brake force distribution)
- Driver's airbag
- Passenger airbag
- IVECO comfort hydraulically-adjustable driver's seat
- Cruise control
- Power steering
- Electronic Immobiliser
- Remote-controlled central locking
- Electric window winders
- Electric exterior mirrors, heated
- Seatbelt anchorage with 5-way height adjustable seatbelts, lowerable
- CD radio including MP3
- Painted front bumper
- Front mudflap
- Fog lights (integrated into main headlights)
- Towing attachment, power socket
- Towing socket preparation
- Spare wheel
- Hazard triangle and first-aid kit
- Entry lights
- Dometic Seitz Mini-Heki 400 x 400 mm roof hood
- Dometic Seitz Midi-Heki 700 x 500 mm roof hood
- Rear garage
- Retractable electric easy-access step
- Framed window
- All windows hinged
- Sprung mattress
- High-quality foam mattress (Alkoven)
- Stainless steel sink with glass lid
- Stainless steel three-burner stove with glass lid
- DOMETIC Tec Tower fridge combination, fridge unit 175 l with 31 l TecTower ice box, oven unit
- Glass cabinet
- THETFORD swivelling cassette toilet with electric flush
- Separate shower
- TRUMA heating Combi 6
- 3M water filter
- Hot water supply in the kitchen and washroom
- High-pressure water pump
- Light operating panel
- 12 V/230 V power supply
- Gel battery, 80 Ah (habitation)
- Onboard control panel
- Additional spots
- Indirect lighting
- Bar in entrance area
- Combi-cassette with blackout pleated fabric and insect protection
- 12-V/230-V power socket and aerial socket
- Lockable living area partition



Wooden decorative trim: Ariolo Birnbaum / Cappuccino

Upholstery: Vulkano

# Layouts

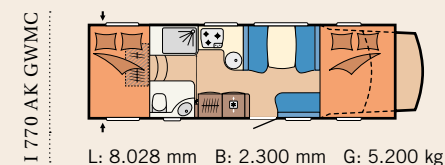
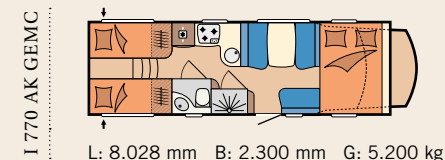

Sun blind, fully integrated (model-specific)



Third brake light



Entry lights



Thermo quarter-light



Garage (model-specific)



Stylish rear lights



Variable storage space



Service hatch locks



3M water filter



High-pressure water pump



Door with security lock



Electric easy-access step





# STANDARD EQUIPMENT



Fresh water tank



Remote-controlled central locking



Insulated and heated waste water tank (model-specific)



Extended exterior mirrors



6-speed manual transmission (model-specific)



Front mudflap



Marker lights

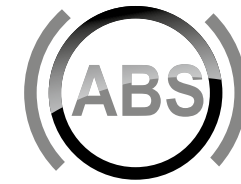

ABS (anti-lock braking system)



ASR (anti-slip control)

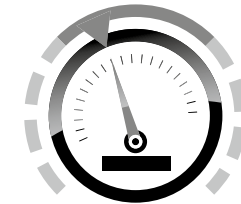

Cruise control



Immobiliser

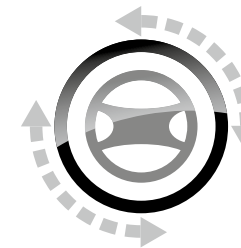

Power steering



Driver's airbag



Roof hood Mini-He-ki (model-specific)



Stylish Washroom Door Handle



DOMETIC SEITZ rooflight 700 x 800 mm (model specific)



Cold foam mattress (model specific)



On board control panel (Toskana Exclusive)



Fridge Slim Tower (model specific)



DOMETIC Tec Tower with Gas Oven (model-specific)



stainless steel sink with glass lid



3 burner hob with glass lid



Interior light control panel (Toskana Exclusive only)



# STANDARD EQUIPMENT



Combi-cassette with high quality pleated flyscreens



Indirect lighting (model-specific)



Additional spots



Roof light in the driver's cab



THETFORD cassette toilet with electric flush and outside vent



CD-Radio FORD Audiosystem 6000 CD illustrated



Seatbelt anchorage with three-point safety belts





Sun blind, fully integrated (model-specific)



Bicycle rack (model-specific)



Special paint finishes (model-specific)



Rear ladder (model-specific)

# EXCLUSIVE TO HOBBY

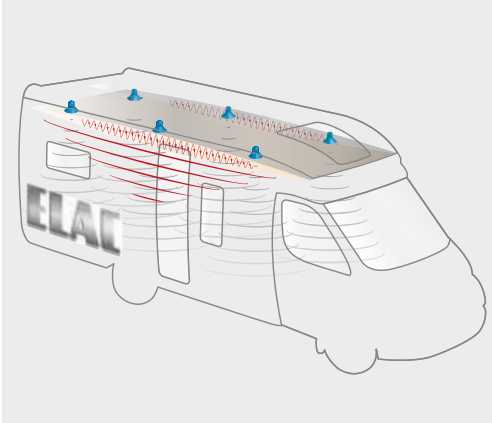

Hobby 'shower of sound'



Reversing camera including navigation device



Hella battery sensor



Height-adjustable pilot seats



Hobby entertainment package



LED lighting package



Webasto parking heating



Alternative upholstery „Vulkano“ (As standard for Sphinx and all Exclusive models)



Alternative upholstery „Lima“ (As standard for Van, Siesta and Toscana)



Alternative upholstery „Havanna“

● Standard fittings ○ Optional extras – not possible

|   | VAN       |            | VAN EXCLUSIVE |             |             | SIESTA        |             |              | SIESTA EXCLUSIVE |           |
|---|-----------|------------|---------------|-------------|-------------|---------------|-------------|--------------|------------------|-----------|
|   | T 500 FSC | T 500 GFSC | TL 500 GFSC   | DL 500 GESC | DL 550 GESC | T 555 AK GFSC | T 600 AK KM | T 650 AK GFM | T 600 FC         | T 650 FLC |
| ESP (electronic stability programme)  | ●         | ●          | ●             | ○           | ○           | ●             | ●           | ●            | ●                | ●         |
| EBD (electronic brake force distribution)   | ●         | ●          | ●             | –           | –           | ●             | ●           | ●            | ●                | ●         |
| Passenger airbag  | ○         | ○          | ○             | ●           | ●           | ○             | ○           | ○            | ○                | ○         |
| Extended exterior mirrors   | ●         | ●          | ●             | –           | –           | ●             | ●           | ●            | ●                | ●         |
| Extended electrically adjustable heated exterior mirrors                                      | ○         | ○          | ○             | ●           | ●           | ○             | ○           | ○            | ○                | ○         |
| Swivelling driver and passenger seats   | ●         | ●          | ●             | ●           | ●           | ●             | –           | –            | ●                | ●         |
| Seatbelt anchorage  | ●         | ●          | ●             | ●           | ●           | ●             | ●           | ●            | –                | ●         |
| Seatbelt anchorage with 5-way height adjustable seatbelts, lowerable                          | –         | –          | –             | –           | –           | –             | –           | –            | ●                | –         |
| CD radio including MP3  | –         | –          | –             | ●           | ●           | –             | –           | –            | –                | –         |
| FORD audio system 6000 with CD player   | ●         | ●          | ●             | –           | –           | ●             | ●           | ●            | ●                | ●         |
| Double glazing, slightly tinted   | ●         | ●          | ●             | –           | –           | ●             | ●           | ●            | ●                | ●         |
| Tyre repair kit   | ●         | ●          | ●             | ●           | ●           | ●             | ●           | ●            | ●                | ●         |
| Spare wheel   | –         | –          | –             | –           | –           | –             | –           | –            | –                | –         |
| Rear garage   | –         | ●          | ●             | ●           | ●           | ●             | ●           | ●            | –                | –         |
| Sprung mattress   | –         | –          | –             | –           | –           | –             | –           | –            | ●                | ●         |
| Cold-foam mattress  | ●         | ●          | ●             | ●           | ●           | ●             | –           | ●            | –                | –         |
| Stainless steel three-burner stove with glass lid   | ●         | ●          | ●             | ●           | ●           | ●             | ●           | ●            | ●                | ●         |
| THETFORD stove with oven unit   | –         | –          | –             | –           | –           | –             | –           | –            | –                | –         |
| DOMETIC fridge 96 l with 9 l removable ice box  | ●         | ●          | ●             | –           | –           | ●             | –           | –            | –                | –         |
| DOMETIC fridge 107 l with 11 l removable ice box  | –         | –          | –             | ●           | –           | –             | –           | –            | –                | –         |
| THETFORD fridge 112 l with 14 l removable ice box   | –         | –          | –             | –           | –           | –             | –           | –            | –                | –         |
| DOMETIC Slim Tower fridge – 140 l fridge with 12 l ice box                                    | –         | –          | –             | –           | –           | –             | ●           | –            | –                | –         |
| DOMETIC fridge combination, fridge capacity 150 l with 26 l ice box                           | –         | –          | –             | –           | ●           | –             | –           | ●            | –                | –         |
| DOMETIC Tec Tower fridge combination, fridge unit 150 l with 26 l TecTower ice box, oven unit | –         | –          | –             | –           | –           | –             | –           | –            | ●                | ●         |
| DOMETIC Tec Tower fridge combination, fridge unit 175 l with 26 l TecTower ice box, oven unit | –         | –          | –             | –           | –           | –             | –           | –            | –                | –         |
| Clip for rubbish bag  | ●         | ●          | ●             | ●           | ●           | ●             | ●           | ●            | –                | –         |
| TRUMA heating Combi 4   | ●         | ●          | ●             | ●           | ●           | ●             | ●           | ●            | ●                | ●         |
| TRUMA heating Combi 6   | –         | –          | –             | –           | –           | –             | –           | –            | –                | –         |
| TRUMA heating Combi 6 E   | ○         | ○          | ○             | ○           | ○           | ○             | ○           | ○            | ○                | ○         |
| Charger/transformer   | 16 Ah     | 16 Ah      | 22 Ah         | 22 Ah       | 22 Ah       | 16 Ah         | 16 Ah       | 16 Ah        | 22 Ah            | 22 Ah     |
| Vulcano upholstery combination  | ○         | ○          | ●             | ●           | ●           | ○             | ○           | ○            | ●                | ●         |
| Lima upholstery combination   | ●         | ●          | ○             | ○           | ○           | ●             | ●           | ●            | ○                | ○         |
| Havanna upholstery combination  | ○         | ○          | ○             | ○           | ○           | ○             | ○           | ○            | ○                | ○         |
| Leather upholstery (cream, brown & cream or black)  | ○         | ○          | ○             | ○           | ○           | ○             | ○           | ○            | ○                | ○         |

# SPECIFICATIONS

| TOSKANA  |           | TOSKANA EXCLUSIVE |            |            |            |              |           |           |             |             | SPHINX        |               |
|----------|-----------|-------------------|------------|------------|------------|--------------|-----------|-----------|-------------|-------------|---------------|---------------|
| D 600 FL | D 650 ESC | D 650 FLC         | D 690 GFLC | D 690 GELC | D 690 GQSC | D 690 H GFLC | D 750 ELC | D 750 FLC | D 750 H FLC | D 750 H UCC | I 770 AK GEMC | I 770 AK GWMC |
| ○        | ○         | ○                 | ○          | ○          | ○          | ○            | ○         | ○         | ○           | ○           | ●             | ●             |
| —        | —         | —                 | —          | —          | —          | —            | —         | —         | —           | —           | —             | —             |
| ●        | ●         | ●                 | ●          | ●          | ●          | ●            | ●         | ●         | ●           | ●           | ●             | ●             |
| —        | —         | —                 | —          | —          | —          | —            | —         | —         | —           | —           | —             | —             |
| ●        | ●         | ●                 | ●          | ●          | ●          | ●            | ●         | ●         | ●           | ●           | ●             | ●             |
| ●        | ●         | ●                 | ●          | ●          | ●          | ●            | ●         | ●         | ●           | ●           | —             | —             |
| ●        | ●         | ●                 | ●          | ●          | ●          | ●            | ●         | ●         | ●           | ●           | —             | —             |
| —        | —         | —                 | —          | —          | —          | —            | —         | —         | —           | —           | ●             | ●             |
| ●        | ●         | ●                 | ●          | ●          | ●          | ●            | ●         | ●         | ●           | ●           | ●             | ●             |
| —        | —         | —                 | —          | —          | —          | —            | —         | —         | —           | —           | —             | —             |
| —        | —         | —                 | —          | —          | —          | —            | —         | —         | —           | —           | —             | —             |
| ●        | ●         | ●                 | ●          | ●          | ●          | ●            | —         | —         | —           | —           | —             | —             |
| —        | —         | —                 | —          | —          | —          | —            | ●         | ●         | ●           | ●           | ●             | ●             |
| —        | —         | —                 | ●          | ●          | ●          | ●            | —         | —         | —           | —           | ●             | ●             |
| ●        | —         | ●                 | —          | ●          | —          | —            | ●         | ●         | —           | —           | ●             | ●             |
| —        | ●         | —                 | ●          | —          | ●          | ●            | —         | —         | —           | ●           | —             | —             |
| ●        | ●         | ●                 | ●          | ●          | ●          | ●            | —         | —         | —           | —           | ●             | ●             |
| —        | —         | —                 | —          | —          | —          | —            | ●         | ●         | ●           | ●           | —             | —             |
| —        | —         | —                 | —          | —          | —          | —            | —         | —         | —           | —           | —             | —             |
| —        | ●         | —                 | —          | —          | —          | —            | —         | —         | —           | —           | —             | —             |
| ●        | —         | —                 | —          | —          | —          | —            | —         | —         | —           | —           | —             | —             |
| —        | —         | —                 | —          | —          | —          | —            | —         | —         | —           | —           | —             | —             |
| —        | —         | —                 | —          | —          | —          | —            | —         | —         | —           | ●           | —             | —             |
| —        | —         | ●                 | ●          | ●          | ●          | ●            | ●         | ●         | ●           | —           | —             | —             |
| —        | —         | —                 | —          | —          | —          | —            | —         | —         | —           | —           | ●             | ●             |
| —        | ●         | —                 | —          | —          | —          | —            | —         | —         | —           | —           | —             | —             |
| ●        | ●         | ●                 | ●          | ●          | ●          | ●            | —         | —         | —           | —           | —             | —             |
| —        | —         | —                 | —          | —          | —          | —            | ●         | ●         | ●           | ●           | ●             | ●             |
| ○        | ○         | ○                 | ○          | ○          | ○          | ○            | ○         | ○         | ○           | ○           | ○             | ○             |
| 16 Ah    | 16 Ah     | 22 Ah             | 22 Ah      | 22 Ah      | 22 Ah      | 22 Ah        | 22 Ah     | 22 Ah     | 22 Ah       | 22 Ah       | 22 Ah         | 22 Ah         |
| ○        | ○         | ●                 | ●          | ●          | ●          | ●            | ●         | ●         | ●           | ●           | ●             | ●             |
| ●        | ●         | ○                 | ○          | ○          | ○          | ○            | ○         | ○         | ○           | ○           | ○             | ○             |
| ○        | ○         | ○                 | ○          | ○          | ○          | ○            | ○         | ○         | ○           | ○           | ○             | ○             |
| ○        | ○         | ○                 | ○          | ○          | ○          | ○            | ○         | ○         | ○           | ○           | ○             | ○             |

| MODEL SERIES      |               | Base vehicle Chassis | Drive type <sup>7</sup> | Threepoint seat belt | Length mm | Width mm | Height mm | Interior standing height mm | Wheelbase mm | Technically permissible gross weight <sup>1</sup> kg | Weight in travel-ready state <sup>2</sup> kg | Load <sup>3</sup> kg |
|-------------------|---------------|----------------------|-------------------------|----------------------|-----------|----------|-----------|-----------------------------|--------------|--|--|----------------------|
| VAN               | T 500 FSC     | FORD Transit 350     | F                       | 4                    | 5.999     | 2.140    | 2.710     | 1.910                       | 3.300        | 3.500  | 2.697  | 803                  |
|                   | T 500 GFSC    | FORD Transit 350     | F                       | 4                    | 5.999     | 2.140    | 2.710     | 1.910                       | 3.300        | 3.500  | 2.697  | 827                  |
| VAN EXCLUSIVE     | TL 500 GESC   | FORD Transit 350     | F                       | 4                    | 6.750     | 2.180    | 2.710     | 1.910                       | 3.750        | 3.500  | 2.853  | 647                  |
| VAN EXCLUSIVE DL  | DL 500 GESC   | FIAT Ducato          | F                       | 4                    | 6.947     | 2.240    | 2.740     | 1.950                       | 3.800        | 3.500  | 2.952  | 548                  |
|                   | DL 550 GESC   | FIAT Ducato          | F                       | 4                    | 7.276     | 2.240    | 2.740     | 1.950                       | 4.035        | 3.500  | 3.051  | 449                  |
| SIESTA            | T 555 AK GFSC | FORD Transit 350     | F                       | 4                    | 5.999     | 2.286    | 2.940     | 2.050                       | 3.300        | 3.500  | 2.863  | 637                  |
|                   | T 600 AK KM   | FORD Transit 350     | F                       | 4                    | 6.407     | 2.286    | 2.940     | 2.050                       | 3.750        | 3.500  | 2.981  | 519                  |
|                   | T 650 AK GFM  | FORD Transit 350     | F                       | 4                    | 6.923     | 2.286    | 2.940     | 2.050                       | 3.750        | 3.500  | 3.068  | 432                  |
| SIESTA EXCLUSIVE  | T 600 FC      | FORD Transit 350     | F                       | 3                    | 6.452     | 2.360    | 2.830     | 1.990                       | 3.750        | 3.500  | 2.856  | 644                  |
|                   | T 650 FLC     | FORD Transit 350     | F                       | 4                    | 6.955     | 2.360    | 2.830     | 1.990                       | 3.750        | 3.500  | 2.997  | 503                  |
| TOSKANA           | D 600 FL      | FIAT Ducato          | F                       | 4                    | 6.470     | 2.330    | 2.870     | 2.037                       | 3.800        | 3.500  | 2.882  | 618                  |
|                   | D 650 ESC     | FIAT Ducato          | F                       | 4                    | 6.968     | 2.330    | 2.870     | 2.037                       | 3.800        | 3.500  | 2.932  | 568                  |
| TOSKANA EXCLUSIVE | D 650 FLC     | FIAT Ducato          | F                       | 4                    | 6.968     | 2.310    | 2.870     | 1.982                       | 3.800        | 3.500  | 3.072  | 428                  |
|                   | D 690 GFLC    | FIAT Ducato          | F                       | 4                    | 7.465     | 2.310    | 2.870     | 2.037                       | 4.035        | 3.500  | 3.208  | 292                  |
|                   | D 690 GELC    | FIAT Ducato          | F                       | 4                    | 7.465     | 2.310    | 2.870     | 1.982                       | 4.035        | 3.500  | 3.224  | 276                  |
|                   | D 690 GQSC    | FIAT Ducato          | F                       | 4                    | 7.465     | 2.310    | 2.870     | 1.982                       | 4.035        | 3.500  | 3.207  | 293                  |
|                   | D 690 H GFLC  | FIAT Ducato          | F                       | 4                    | 7.465     | 2.310    | 2.952     | 2.092                       | 4.035        | 4.000  | 3.331  | 669                  |
|                   | D 750 ELC     | FIAT Ducato          | F                       | 4                    | 8.047     | 2.310    | 2.910     | 1.982                       | 4.316        | 4.500  | 3.693  | 807                  |
|                   | D 750 FLC     | FIAT Ducato          | F                       | 4                    | 8.047     | 2.310    | 2.910     | 1.982                       | 4.316        | 4.500  | 3.689  | 811                  |
|                   | D 750 H FLC   | FIAT Ducato          | F                       | 4                    | 8.047     | 2.310    | 2.965     | 2.037                       | 4.316        | 4.500  | 3.802  | 698                  |
| SPHINX            | I 770 AK GEMC | IVECO Daily          | H                       | 4                    | 8.028     | 2.300    | 3.290     | 2.080                       | 4.750        | 5.200  | 4.183  | 1.017                |
|                   | I 770 AK GWMC | IVECO Daily          | H                       | 4                    | 8.028     | 2.300    | 3.290     | 2.080                       | 4.750        | 5.200  | 4.165  | 1.035                |

<sup>1</sup> The technically permissible gross weight must not be exceeded under any circumstances.

<sup>2</sup> The weight of the vehicle in ready-to-drive state corresponds to the weight of the empty vehicle, including lubricants, on-board tools, spare wheel (repair kit where appropriate), fuel (100%), extra battery, all standard

factory-fitted equipment and 75 kg for the driver in addition to the basic equipment. Basic equipment comprises the weight of the fresh water and gas containers, which are filled to 90% of their capacity.



# TECHNICAL DATA

| Towing weight <sup>4</sup><br>braked<br>kg | Body strength<br>mm | Fresh water<br>volume in<br>Litre | Waste water<br>volume in<br>Litre | Room for<br>gas canisters<br>kg | Number<br>of seats | Number<br>of beds | Bed area, over-cab<br>mm | Bed area, centre<br>mm | Bed area, rear<br>mm      |               |
|--|---------------------|-----------------------------------|-----------------------------------|---------------------------------|--------------------|-------------------|--------------------------|------------------------|---------------------------|---------------|
| 1.000                                      | 34 / 34 / 41        | 100                               | 92                                | 2 x 11                          | 4                  | 3                 | –                        | 1.960 x 1.065 / 470    | 1.960 x 1.300             | T 500 FSC     |
| 1.000                                      | 34 / 34 / 41        | 100                               | 92                                | 2 x 11                          | 4                  | 3                 | –                        | 1.960 x 1.065 / 470    | 1.960 x 1.300             | T 500 GFSC    |
| 1.000                                      | 34 / 34 / 41        | 100                               | 92                                | 2 x 11                          | 4                  | 3                 | –                        | 1.970 x 1.065 / 470    | 2 x 1.980 x 765           | TL 500 GESC   |
| 1.600                                      | 34 / 34 / 63        | 100                               | 92                                | 2 x 11                          | 4                  | 3                 | –                        | 2.050 x 1.120 / 520    | 2 x 1.980 x 800           | DL 500 GESC   |
| 1.600                                      | 34 / 34 / 63        | 100                               | 92                                | 2 x 11                          | 4                  | 3                 | –                        | 2.050 x 1.065 / 780    | 1.950 x 800 / 2.020 x 800 | DL 550 GESC   |
| 1.000                                      | 34 / 34 / 90        | 100                               | 92                                | 2 x 11                          | 4                  | 5                 | 2.100 x 1.500            | 2.100 x 1.050 / 490    | 2.100 x 1.300             | T 555 AK GFSC |
| 1.000                                      | 34 / 34 / 90        | 100                               | 92                                | 2 x 11                          | 4 <sup>6</sup>     | 6                 | 2.100 x 1.500            | 1.900 x 1.350          | 2 x 2.100 x 760           | T 600 AK KM   |
| 1.000                                      | 34 / 34 / 90        | 100                               | 92                                | 2 x 11                          | 4 <sup>6</sup>     | 6                 | 2.100 x 1.500            | 1.900 x 1.350          | 2.100 x 1.380 / 1.290     | T 650 AK GFM  |
| 1.000                                      | 34 / 34 / 90        | 100                               | 92                                | 2 x 11                          | 3                  | 3                 | –                        | 2.180 x 930 / 550      | 1.995 x 1.300 / 1.060     | T 600 FC      |
| 1.000                                      | 34 / 34 / 90        | 100                               | 92                                | 2 x 11                          | 4                  | 4                 | –                        | 2.180 x 1.280 / 990    | 1.970 x 1.300 / 1.020     | T 650 FLC     |
| 1.600                                      | 34 / 34 / 63        | 100                               | 92                                | 2 x 11                          | 4                  | 4                 | –                        | 1.840 x 1.400          | 1.960 x 1.310 / 950       | D 600 FL      |
| 1.600                                      | 34 / 34 / 63        | 100                               | 92                                | 2 x 11                          | 4                  | 4                 | –                        | 2.115 x 1.128 / 525    | 2 x 800 x 2.050           | D 650 ESC     |
| 1.600                                      | 34 / 34 / 120       | 100                               | 92                                | 2 x 11                          | 4                  | 4                 | –                        | 2.160 x 1.260 / 1.000  | 1.930 x 1.300 / 950       | D 650 FLC     |
| 1.600                                      | 34 / 34 / 65        | 100                               | 92                                | 2 x 11                          | 3 <sup>5</sup>     | 4                 | –                        | 2.160 x 1.750 / 1.450  | 2.180 x 1.450             | D 690 GFLC    |
| 1.600                                      | 34 / 34 / 120       | 100                               | 92                                | 2 x 11                          | 3 <sup>5</sup>     | 4                 | –                        | 2.160 x 1.260 / 900    | 2 x 2.040 x 840           | D 690 GELC    |
| 1.600                                      | 34 / 34 / 120       | 100                               | 92                                | 2 x 11                          | 3 <sup>5</sup>     | 3                 | –                        | 2.160 x 1.050 / 680    | 1.950 x 1.500             | D 690 GQSC    |
| 1.600                                      | 34 / 34 / 65        | 100                               | 92                                | 2 x 11                          | 4                  | 4                 | –                        | 1.400 x 1.900          | 2.180 x 1.450             | D 690 H GFLC  |
| 1.550                                      | 34 / 34 / 41 / 19   | 100                               | 100                               | 2 x 11                          | 4                  | 4                 | –                        | 2.160 x 1.410 / 900    | 1.960 x 820 / 1.820 x 820 | D 750 ELC     |
| 1.550                                      | 34 / 34 / 41 / 19   | 100                               | 100                               | 2 x 11                          | 4                  | 4                 | –                        | 2.160 x 1.840 / 1.450  | 1.930 x 1.300 / 950       | D 750 FLC     |
| 1.550                                      | 34 / 34 / 41 / 19   | 100                               | 100                               | 2 x 11                          | 4                  | 4                 | –                        | 1.900 x 1.400          | 1.930 x 1.300 / 950       | D 750 H FLC   |
| 1.550                                      | 34 / 34 / 41 / 19   | 100                               | 100                               | 2 x 11                          | 3                  | 2 + 2             | –                        | –                      | 1.900 x 1.400             | D 750 H UCC   |
| 3.000                                      | 34 / 34 / 41 / 19   | 200                               | 200                               | 2 x 11                          | 4 <sup>6</sup>     | 6                 | 2.150 x 1.500            | 1.820 x 1.350          | 2 x 1.960 x 820           | I 770 AK GEMC |
| 3.000                                      | 34 / 34 / 41 / 19   | 200                               | 200                               | 2 x 11                          | 4 <sup>6</sup>     | 6                 | 2.150 x 1.500            | 1.820 x 1.350          | 2.160 x 1.400             | I 770 AK GWMC |

The basic fittings for the following models weigh  
 Van: 110 kg  
 Siesta: 110 kg  
 Siesta Exclusive: 110 kg  
 Toskana: 110 kg  
 Toskana Exclusive: 110 kg  
 Sphinx: 200 kg

<sup>3</sup> The loading corresponds to the difference between the „technically permissible gross weight“ and the „ready-to-travel state“. This value must take account of the values for passenger, optional accessories and personal items.

<sup>4</sup> The towing attachment is a special accessory. Please comply with the maximum permitted towing weight.

<sup>5</sup> With load capacity raised to 3,850 kg or 4,000 kg the number of seats rises from 3 to 4.



<sup>6</sup> With the „additional seatbelt anchorage“ option, a license for six people can be obtained.

<sup>7</sup> Drive type  
 F: Front wheel drive  
 H: Rear wheel drive



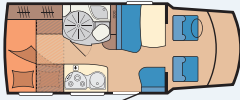

VAN





**VAN CLASSIC T 500 FSC** 





F L: 5.999 mm B: 2.140 mm G: 3.500 kg

   

**VAN CLASSIC T 500 GFSC** 





F L: 5.999 mm B: 2.140 mm G: 3.500 kg

   

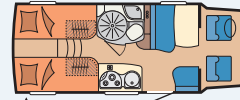
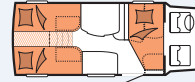

**VAN EXCLUSIVE TL 500 GESC** 



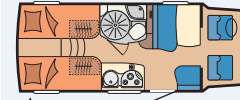

F L: 6.750 mm B: 2.180 mm G: 3.500 kg

**VAN EXCLUSIVE DL 500 GESC** 

F L: 6.947 mm B: 2.240 mm G: 3.500 kg

OVER-CAB AREAS





**SIESTA T 555 AK GFSC** 







F L: 5.999 mm B: 2.286 mm G: 3.500 kg

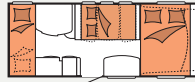



**SIESTA T 600 AK KM** 





F L: 6.407 mm B: 2.286 mm G: 3.500 kg

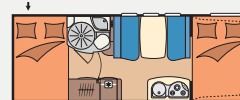



**SIESTA T 650 AK GFM** 



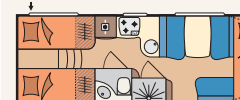

F L: 6.923 mm B: 2.286 mm G: 3.500 kg

**SPHINX I 770 AK GEMC** 







H L: 8.028 mm B: 2.300 mm G: 5.200 kg



LOW PROFILE





**SIESTA EXCLUSIVE T 600 FC** 



F L: 6.452 mm B: 2.360 mm G: 3.500 kg

  

**SIESTA EXCLUSIVE T 650 FLC** 



F L: 6.955 mm B: 2.360 mm G: 3.500 kg

  

**TOSKANA D 600 FL** 

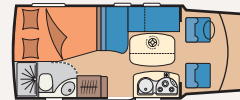
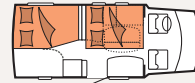

F L: 6.470 mm B: 2.330 mm G: 3.500 kg

  

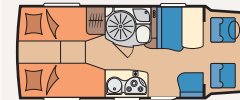
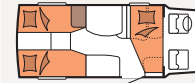

**TOSKANA D 650 ESC** 





F L: 6.968 mm B: 2.330 mm G: 3.500 kg

  



**TOSKANA EXCLUSIVE D 690 GFLC** 





F L: 7.465 mm B: 2.310 mm G: 3.500 kg

   



**TOSKANA EXCLUSIVE D 690 GELC** 





F L: 7.465 mm B: 2.310 mm G: 3.500 kg

   

**TOSKANA EXCLUSIVE D 690 GQSC** 



F L: 7.465 mm B: 2.310 mm G: 3.500 kg

**TOSKANA EXCLUSIVE D 750 ELC** 



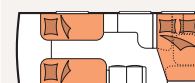

F L: 8.047 mm B: 2.310 mm G: 4.500 kg

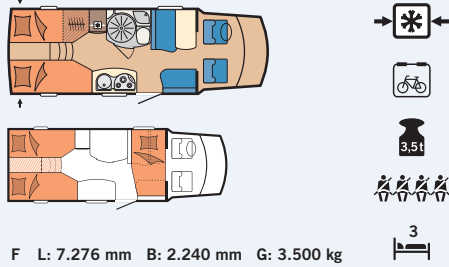

# LAYOUTS

VAN EXCLUSIVE DL 550 GESC



SPHINX I 770 AK GWMC

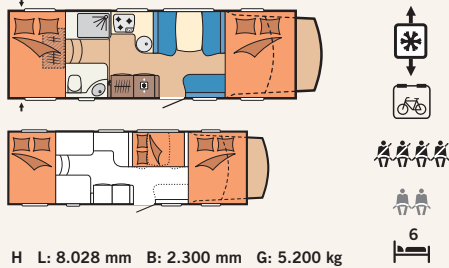

TOSKANA EXCLUSIVE D 650 FLC

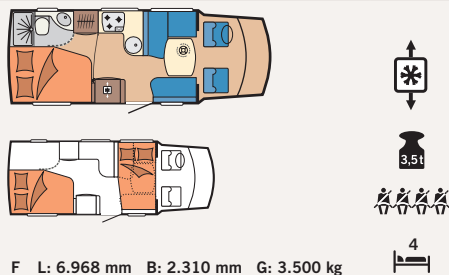

TOSKANA EXCLUSIVE D 750 FLC

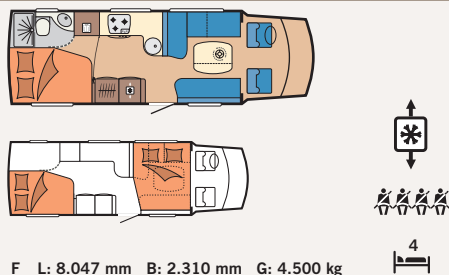

TOSKANA EXCLUSIVE D 690 H GFLC

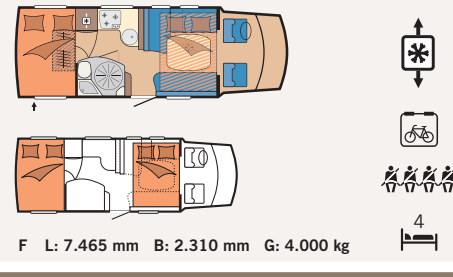

TOSKANA EXCLUSIVE D 750 H FLC

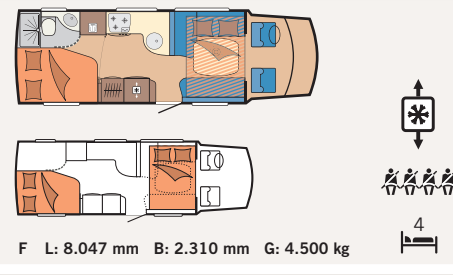

TOSKANA EXCLUSIVE D 750 H UCC

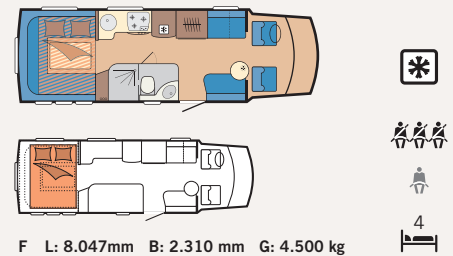

LOW PROFILE WITH DROP DOWN BED

## TECHNICAL DATA

- L: total length
- B: total width
- G: Technically permissible gross weight
- F: Front wheel drive
- H: Rear wheel drive

## EXPLANATION OF SYMBOLS

- |  |                                 |    |                       |
|--|---------------------------------|----|-----------------------|
|  | Beds                            | AK | Over-cab areas        |
|  | Lift-away bed / bed extension   | C  | Couch                 |
|  | Seating area                    | E  | Single beds           |
|  | Cabinet                         | F  | Fixed bed             |
|  | Wardrobe                        | K  | Children's beds       |
|  | Linen cupboard                  | H  | Lift-away bed         |
|  | Kitchenette                     | L  | L-seating area        |
|  | Fridge                          | M  | Central seating area  |
|  | Fridge Slim Tower               | S  | Side seating area     |
|  | Fridge Tec Tower                | Q  | Queen size bed        |
|  | Washroom                        | U  | Circular seating unit |
|  | Worktop/table                   | W  | Washroom              |
|  | Floor                           | G  | Garage                |
|  | Garage door                     |    |                       |
|  | Number of beds                  |    |                       |
|  | Number of belted seats          |    |                       |
|  | Additional seatbelts (optional) |    |                       |
|  | 3,5 t                           |    |                       |
|  | Garage                          |    |                       |

The figures are not to scale!

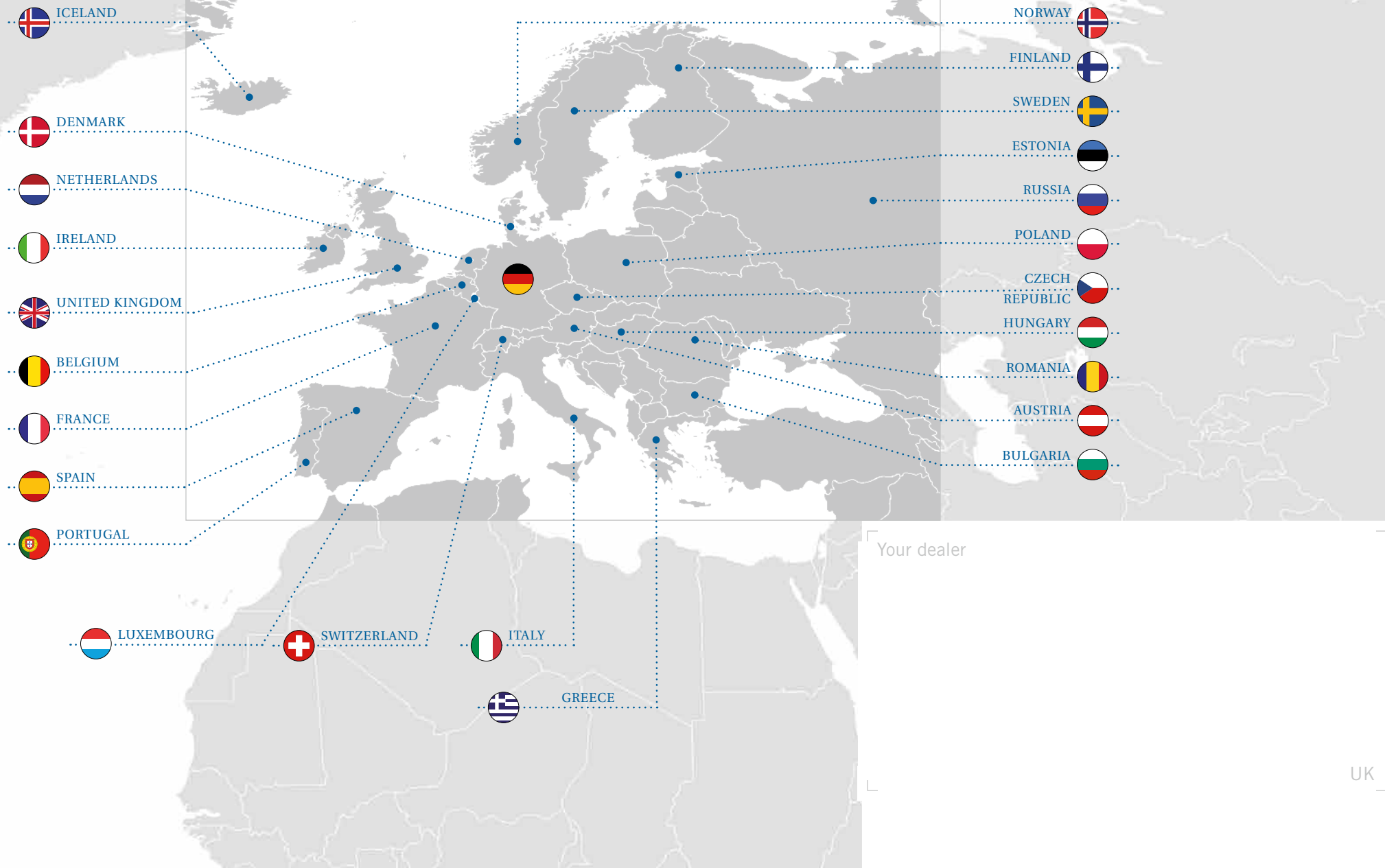

**GERMANY**



**Hobby-Wohnwagenwerk**

Ing. Harald Striewski GmbH  
 Harald-Striewski-Straße 15  
 D-24787 Fockbek/Rendsburg

[www.hobby-caravan.de](http://www.hobby-caravan.de)

**NOTE**

the models featured in the brochure also currently have optional extras or decoration that are not part of the standard scope of delivery. Deviations in terms of structure and colour compared to the featured furnishings are subject to change provided they have to do with the nature of the materials used and are found in the trade. The same applies to technical changes to the vehicle provided the product quality remains the same overall or is improved and the purpose of use is not impaired.